

TRI-GARD 510

AUDIO GLASSBREAK DETECTOR



510

TRI-GARD 510 AUDIO DETECTOR

The Tri-Gard is a patented passive sonic glassbreak detector designed to detect the sound signals produced by the breaking of most types of uncovered glass, including 1/8" and 1/4" plate glass and 1/4" wired glass.

The Tri-Gard features two individual stages of frequency filtering, providing excellent rejection of audio signals out of the glassbreak spectrum, and patented signal processing which analyzes all three sound dimensions- "Amplitude" (loudness), "Frequency" (tone, pitch) and the "Rate of Change" of the amplitude and/or frequency.

The maximum range is up to 60 feet from the unit in an open area - hard acoustical environment. The IEI-510 is self adjusting to compensate for background noise and/or rising audio signals.

The TRI-GARD utilizes 3 LED'S to provide a constant visual readout. The green LED indicates power on normal status. The amber LED shows a reading of both amplitude and frequency. The red LED shows an alarm condition. The red LED can either automatically reset or can latch-in requiring the unit to be reset by power interruption. The unit will still detect with the LED on.

TRI-GARD 510 FEATURES

- Patented state of the art three dimensional signal processing
- Automatic tracking level
- Analysis of the three sound dimensions: amplitude, frequency and rate of rise or rate of change
- 60' maximum range
- 3 LED indicators
- Contemporary styling

INSTRUCTION BULLETIN

510 # 615-1000



SPECIFICATIONS

SENSING: Audio/air, open space (enclosed area)

RANGE: 60 ft. radius

FREQUENCY SPECTRUM: 4.1KHZ - 16KHZ

AMPLITUDE SPECTRUM: 74DB @ 5KHZ / C SCALE- ADJUSTABLE (MAX)

SENSING FIELD: Omni-directional

SENSOR: Electret condenser (F.E.T. pre-amp)

DISCRIMINATION: AMPLITUDE/FREQUENCY/DISTANCE/RATE OF RISE

SET UP ADJUSTMENTS: SENSITIVITY/ MEMORY LATCH RED LED

INDICATORS: GREEN LED- STATUS NORMAL

RED LED- ALARM CONDITION

AMBER LED- AMPLITUDE AND FREQUENCY

OPERATING VOLTAGE: 10.5-16 VDC filtered and regulated

VOLTAGE MONITOR: LOW OR NO VOLTAGE CAUSES ALARM ACTIVATION

VOLTAGE SUPERVISION: ALARM RELAY

POWER CONSUMPTION: 44 ma @ 13.6 VDC normal, 50 ma max

OPERATING TEMPERATURE: 14° to 120° F. (-10° to 49° C)

RELAY ACTIVATION TIME: 3 seconds

ALARM LED: Latch or auto reset

ALARM RELAY: SPDT (Form-C)- contacts 1 Amp @30 VAC/24 VDC

TAMPER CIRCUIT: Normally closed switch-contacts .1 Amp @ 30 VAC/24 VDC.

INSTALLATION: Hardwire 6 wires including 2 for tamper MOUNTING:

Surface- screw and anchors included

COLOR: White or Cabin Brown

SIZE: 3" x 3" x .79"

WEIGHT: 2.2 OUNCES

MOUNTING SCREW: #4 x 3/4" SLOTTED

PILOT HOLE- SCREW: 1/16"

PILOT HOLE- ANCHOR: 3/16"

MOUNTING LOCATIONS

The IEI-510 Tri-Gard detection is omni-directional (360°) and should be located as close as possible to the glass being protected. Maintain equal distances from multiple panes. The unit may be wall or ceiling mounted.

IEI-510 OPTIMUM LOCATIONS

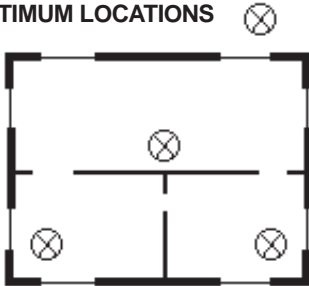

NOTE: Do not mount the detector on the same wall as the protected surface. Do not obstruct the detector with partitions or barriers. Do not locate the detector within 30 feet of electro-mechanical bells having a diameter of 1-5" or air compressors which may be activated while the system is in the armed condition.

INSTALLATION AND WIRING

Run power and alarm loop to unit. Concealed wiring may enter through square hole in base. Surface wire uses notch in case top. The unit may be mounted in any orientation. For wood and some types of ceiling tile, use the screw alone. For metal use screws and drill 1/16" pilot hole. For plaster or drywall use anchors provided with screws.

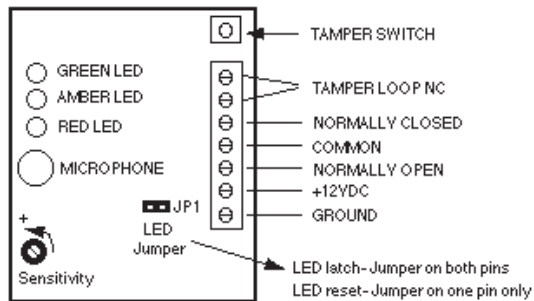

ALARM LED

Auto reset- Remove JP1 jumper from the pins and reinsert on one pin only. On alarm the red alarm LED will light for 3 seconds and reset.

Latch- To latch the red LED in memory leave JP1 on both pins. Interrupt power for 5 seconds to reset latched LED.

Note: Alarm relay will reset after 3 seconds.

TESTING/SENSITIVITY ADJUSTMENT

The sensitivity is increased by rotating the potentiometer counter-clockwise. Rotating the potentiometer clockwise will decrease the sensitivity.

For best results use the IEI-515 glass break simulator and follow the procedure on its label. The tester generates sufficient signal to set the sensitivity as low as possible to prevent nuisance alarms but high enough to detect glass breakage.

NOTE: FINAL TEST WITH THE 515 TESTER MUST BE PERFORMED WITH THE 510 COVER ON.

NOTE: The placement of objects in the room will vary the acoustics. Small displacements of the tester and objects near the 510 can make large differences in the sensitivity setting. This will appear to make the tests inconsistent. Therefore, use this test as a guide for the setting then take into consideration the environment (hard or soft), the distance from the window to the detector and the ambient noise (watch for the yellow led on the 510- it will light if there is too much background noise present). If the tester has the 510 sensitivity set very low, for example, at 30+ foot setting in a living room it is probably a quirk of acoustics and you should set the sensitivity higher. If the yellow led is on frequently during conditions typical to when the alarm system will be armed you may need to reposition the detector and/or lower the sensitivity and add detectors to get the proper coverage.

IEI Limited Warranty:

Because the manufacturer does not install or connect this security device the manufacturer cannot guarantee its performance. Therefore, there are no warranties, expressed or implied (except as stated below), attached to the sale or use of this product.

The manufacturer warrants against defects in material and workmanship in this device for 3 years from the date of manufacture. During the warranty period the manufacturer, at its sole option, will repair or replace free of charge any defective unit returned freight prepaid. This warranty shall remain in force and effect for 3 years provided the unit was properly installed and operated, has not been subject to misuse and has not been repaired or altered other than by the original manufacturer.

The foregoing states the buyer's sole and exclusive remedy for any breach of warranty or for any claim, whether sounding in contract, tort, strict liability, or negligence, based upon any defect in this security device.

The manufacturer shall in no event be responsible for any incidental or consequential damages incurred by the buyer.

This warranty supercedes all previous warranties.



427 TURNPIKE STREET, CANTON, MA 02021 U.S.A.
800-343-9502 OR IN MA 800-733-9502

510 REV. 1.01 615-1000 **MADE IN U.S.A.**