

Hub Door Control Module (DCM) Installation Guide

Note: Please refer the U.L. Listed HubMax/HubMax II Installation/Programming Manual for complete details.

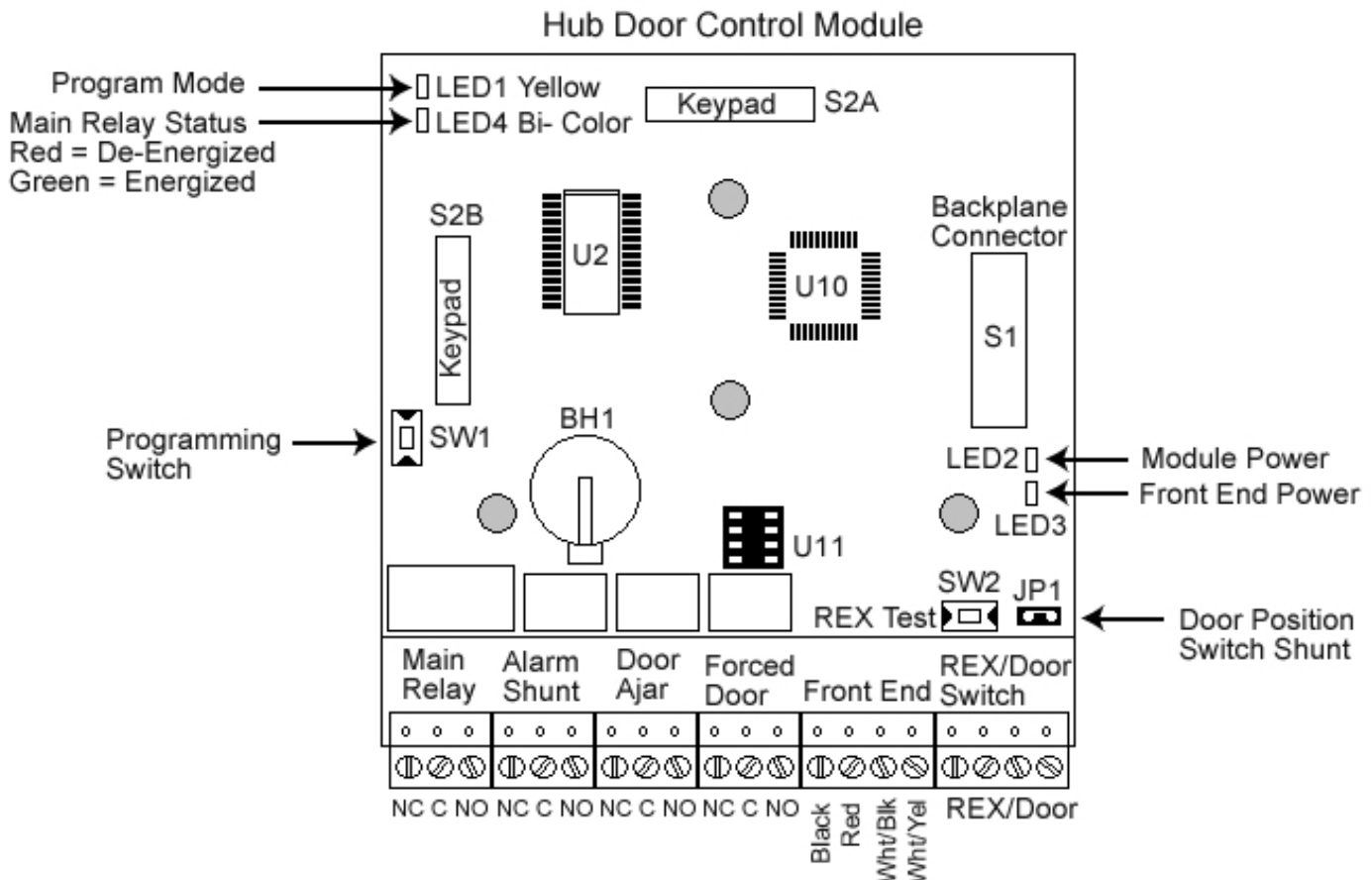

To install additional Hub Door Control Modules:

1. Slide the Door Control Module onto the pin-rail marked Px (x = Expansion Port #; Example: P2) located on the HubMax backplane.
2. Align the 3 holes in the Door Control Module with the standoffs mounted on the backplane.
3. Gently press down on the Module to snap it on onto the standoffs.
4. Turn the Module Power Switch (located on the backplane) to "ON".

TOUCH THE METAL CABINET BEFORE TOUCHING THE BACKPLANE OR HUB DOOR CONTROL MODULE. THIS REMOVES ANY STATIC CHARGE FROM A PERSON. STATIC ELECTRICITY CAN DAMAGE THE ELECTRONIC COMPONENTS USED IN THE HUBMAX MODULE ACCESS SYSTEM.

Programming the Door Number on a newly installed Hub Door Control Module

Note: All Hub DCMs are factory programmed as Door Number 01.

To program the Door Number:

COMMAND	ACTION	COMMENT
Enter Program Mode	99 # MASTER CODE * (yellow LED begins to flash) Note: The default master code is 1234	If the Master Code is unknown, enter program mode by pressing the SW1 switch on the DCM. Hold SW1 for 1 second and release.
Program DOOR NUMBER	43 # 0 # DOOR NUMBER # **	The Door Number must be a two-digit number. (Ex: 01, 02, 03...up to 32).
Exit Program Mode	* (yellow LED stops flashing)	

International Electronics Incorporated (IEI) warrants its products to be free from defects in material and workmanship, when they have been installed in accordance with the manufacturer's instructions, and have not been modified or tampered with. **IEI does not** assume any responsibility for damage or injury to person or property due to improper care, storage handling, abuse, misuse, normal wear and tear, or an act of God.

IEI's sole responsibility is limited to the repair (at **IEI's** option) or the replacement of the defective product or part when sent to **IEI's** facility (freight and insurance charges prepaid), **after** obtaining **IEI's** Return Merchandise Authorization. **IEI** will not be liable to the purchaser or any one else for incidental or consequential damages arising from any defect in, or malfunction of, its products.

This warranty shall expire two years after shipping date for Door Gard Keypads. Except as stated above, **IEI** makes no warranties, either expressed or implied, as to any matter whatsoever, including, without limitation to, the condition of its products, their merchantability, or fitness for any particular application.



427 Turnpike Street
Canton, MA 02021 U.S.A.
Phone: (781) 821-5566
(800) 733-9502 Sales in MA
(800) 343-9502 Sales
FAX: (781) 821-4443

Fax Information Center: (781) 821-0734

Visit our Web Site at www.ieib.com

IEI TECHNICAL SUPPORT LINE: (800) 343- 9502 (800)733-9502
--