

Linear

PRO ACCESS™

LPASL2000B

Revision E

DC Slide Gate Operator Installation Manual

⚠ **WARNING!** ⚠

This equipment is similar to other gate or door equipment and meets or exceeds Underwriters Laboratory Standard 325 (UL 325). However, gate equipment has hazards associated with its use and therefore by installing this product the installer and user accept full responsibility for following and noting the installation and safety instructions. Failure to follow installation and safety instructions can result in hazards developing due to improper assembly. You agree to properly install this product and that if you fail to do so GTO Access Systems, LLC, ("GTO") shall in no event be liable for direct, indirect, incidental, special or consequential damages or loss of profits whether based in contract tort or any other legal theory during the course of the warranty or at any time thereafter. The installer and/or user agree to assume responsibility for all liability and use of this product releasing GTO Access Systems, LLC, from any and all liability. If you are not in agreement with this disclaimer or do not feel capable of properly following all installation and safety instructions you may return this product for full replacement value.

READ ALL INSTRUCTIONS CAREFULLY AND COMPLETELY before attempting to install and use this automatic gate operator. This gate operator produces a high level of force. Stay clear of the unit while it is operating and exercise caution at all times.

All automatic gate operators are intended for use on vehicular gates only.



**DO NOT INSTALL THIS OPERATOR WITHOUT
SAFETY EDGES AND ROLLER GUARDS!**



ACCESS SYSTEMS, LLC

For more information on the GTO ACCESS SYSTEMS full line of automatic gate operators and access controls visit our website at www.gtoaccess.com.

Class Rating

This Gate Operator is intended for use with **vehicular slide gates in single family residential applications**. The operator is system certified to be in compliance with UL 325, current edition, as of publication date.

Vehicular Gate Operator Class Categories:

Residential Vehicular Gate Operator—Class I: A vehicular gate operator (or system) intended for use in a home of one-to-four single family dwelling, or a garage or parking area associated therewith.

Commercial/General Access Vehicular Gate Operator—Class II: A vehicular gate operator (or system) intended for use in a commercial location or building such as a multifamily housing unit (five or more single family units), hotel, garages, retail store, or other building servicing the general public.

Industrial/Limited Access Vehicular Gate Operator—Class III: A vehicular gate operator (or system) intended for use in an industrial location or building such as a factory or loading dock area or other locations not intended to service the general public.

Restricted Access Vehicular Gate Operator—Class IV: A vehicular gate operator (or system) intended for use in a guarded industrial location or building such as an airport security area or other restricted access locations not servicing the general public, in which unauthorized access is prevented via supervision by security personnel.

Converting Metric Units to English Equivalents

When You Know	Multiply By	To Find	Symbol
centimeters	0.3937	inches	in. (or ")
meters	3.2808	feet	ft. (or')
kilograms	2.2046	pounds	lb. (or #)

Converting English Units to Metric Equivalents

When You Know	Multiply By	To Find	Symbol
inches	2.5400	centimeters	cm
feet	0.3048	meters	m
pounds	0.4535	kilograms	kg

Converting Temperature

deg. Celsius	$(^{\circ}\text{C} \times 1.8) + 32$	deg. Fahrenheit	$^{\circ}\text{F}$
deg. Fahrenheit	$(^{\circ}\text{F} - 32) \div 1.8$	deg. Celsius	$^{\circ}\text{C}$

FOR YOUR RECORDS

Please record the following information product serial number (located on right side of control box), be sure to **keep all receipts for proof of purchase**. Refer to this information when calling GTO for service or assistance with your automatic gate opener.

Serial Number: _____ Date of Purchase: _____

Place of Purchase: _____

Table of Contents

Class Rating	i
Please Read This First.....	iv
Important Safety Instructions	v
Solar Panel and Gate Activity Chart.....	page 1
Technical Specifications	page 2
Parts Identification (Single Gate Operator)	page 3
Single Gate Operator Installation	page 4
Overview and Gate Preparation	page 4
Suggested Conduit & Wiring and Mounting the Legs	page 5
Determining the Mounting Position and Mounting the Operator	page 6
Installing the Chain	page 7
Disconnecting Operator Chain for Manual Operation of Gate	page 7
Powering the System	page 8
Installation of the Transformer.....	page 8
Connecting Solar Panel (s).....	page 9
Control Board Settings	page 10
Program Your Personal Transmitter Setting.....	page 11
Mounting the Receiver	page 12
Adjusting the Limit Switches	page 13
Connecting Safety Devices	page 14
Input Connections	page 15
Connecting Accessories.....	page 16
Attaching the Housing.....	page 17
Dual Gate System Installation	page 18
Preparing the Gates	page 19
Wiring the Second Operator	page 20
Attaching the Housing	page 21
Maintenance	page 22
Troubleshooting Guide.....	page 23
Warranty and Repair Service	page 24
Accessory Catalog	page 25

PLEASE READ THIS FIRST



ACCESS SYSTEMS, LLC

Thank you for purchasing the GTO slide gate operator. When correctly installed and properly used, your gate operator will give you many years of reliable service. Please read the following information to ensure you have the correct system for your particular needs. This manual will enable you to properly install your Automatic Gate Operator.

The operator is designed for installation on a slide-to-open single or dual leaf gates. The gates must not exceed 30 feet in length nor weigh more than 1000 pounds* (please see Technical Specifications on page 2). This operator can be used on vinyl, aluminum, chain link and wrought iron gates.

The operator accommodates extra transmitters, digital keypads, solar panels, push buttons, and other access control products. **These optional accessories are noted with the  symbol.**

The operator features **Dual Sense Technology™**. This safety feature makes the gate stop and reverse direction within two seconds when it comes in contact with an obstruction. The "MIN" setting means the gate will exert the minimum force on an obstruction before it stops and reverses direction.

The operator also has an **adjustable auto-close** feature. It can be set to remain open from 3 to 120 seconds before automatically closing. Pressing the transmitter button at any time after the gate fully opens will cause it to close immediately. "OFF" is the factory setting; meaning the gate will stay open until you press the transmitter button (or keypad, etc.) again.

Please call GTO at (800) 543-GATE [4283] or (850) 575-0176 for more information about our GTO/ACCESS SYSTEMS professional line of gate operators and accessories. Our Sales Department will be glad to give you the name and phone number of a GTO/ACCESS SYSTEMS dealer near you.

BEFORE YOU BEGIN TO INSTALL YOUR AUTOMATIC GATE OPERATOR:

Read these instructions carefully and completely to become familiar with all parts and installation steps. You must read the installation manual for detailed instructions on gate operator safety and proper use of the gate operator.



24/7 Troubleshooting Wizard: <http://support.gtoaccess.com>



GTO Accessories are noted with this symbol in this Installation Manual. Information about accessories can be found on page 26 and at www.gtoaccess.com.

IMPORTANT SAFETY INSTRUCTIONS



Because automatic gate operators produce high levels of force, consumers need to know the potential hazards associated with improperly designed, installed, and maintained automated gate operator systems. *Keep in mind that the gate operator is just one component of the total gate operating system.* Each component must work in unison to provide the consumer with convenience, security, and safety.

This manual contains various safety precautions and warnings for the consumer. Because there are many possible applications of the gate operator, the safety precautions and warnings contained in this manual cannot be completely exhaustive in nature. They do, however, provide an overview of the safe design, installation, and use of this product. **CAREFULLY READ AND FOLLOW ALL SAFETY PRECAUTIONS, WARNINGS, AND INSTALLATION INSTRUCTIONS TO ENSURE THE SAFE SYSTEM DESIGN, INSTALLATION, AND USE OF THIS PRODUCT.**

Precautions and warnings in this manual are identified with this  warning symbol. The symbol identifies conditions that can result in damage to the operator or its components, serious injury, or death.

Because GTO automatic gate operators are only part of the total gate operating system, it is the responsibility of the installer/consumer to ensure that the total system is safe for its intended use.

How To Manually Open and Close the Gate:

 **CAUTION:** Disconnect the operator chain **ONLY** when the power switch and control board is off.

Disconnecting the Operator

1. Lift the quick release pins UP, then pull them OUT of the chain brackets (see illustration).
2. Lay the chain down and manually slide the gate to the desired position.

 **CAUTION:** Because the GTO gate operator is battery powered, disconnect the operator **ONLY** when the power switch on the control box is turned OFF. Unplugging the transformer does not turn power to the operator OFF.

NOTE: To prevent unauthorized removal of the quick release pins, install  [FM345] pin locks (see accessory catalog pg. 26) above the quick release pins in both chain brackets.

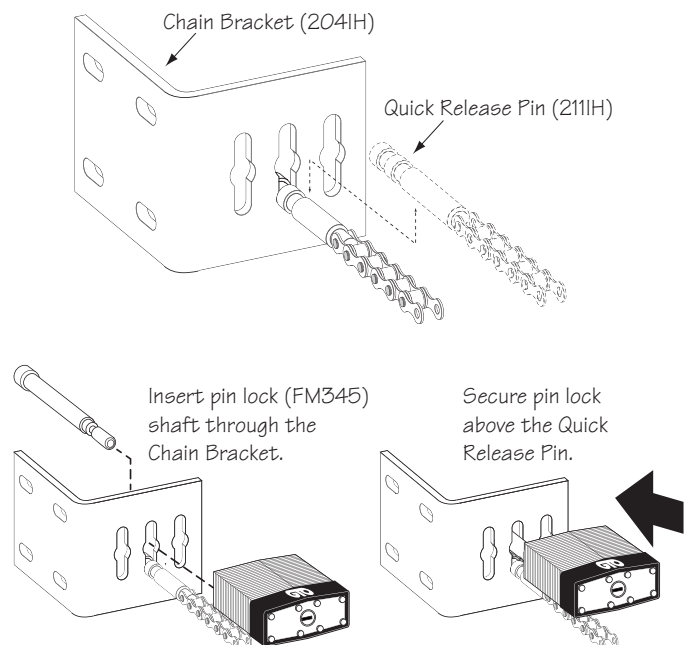



IMPORTANT SAFETY INSTRUCTIONS

For The System Designer

⚠ WARNING: To reduce the risk of injury or death:

1. **READ AND FOLLOW ALL INSTRUCTIONS.** Failure to meet the requirements set forth in the instruction manual could cause severe injury or death, for which the manufacturer cannot be held responsible.
2. When designing a system that will be entered from a highway or main thoroughfare, make sure the system is placed far enough from the road to prevent traffic congestion.
3. The gate must be installed in a location that provides adequate clearance between it and adjacent structures when opening and closing to reduce the risk of entrapment.
4. The gate and gate operator installation **must comply with any applicable local codes.**

I. Before Installation

1. Verify this operator is proper for the type and size of gate, its frequency of use, and the proper class rating.
2. Make sure the gate has been properly installed and slides freely in both directions. Repair or replace all worn or damaged gate hardware prior to installation. A freely moving gate will require less force to operate and will enhance the performance of the operator and safety devices used with the system.
3. Review the operation of the system to become familiar with its safety features. Understand how to disconnect the operator for manual gate operation (page v).
4. This gate operator is intended for vehicular gates **ONLY**. A separate entrance or gate must be installed for pedestrian use (page viii).
5. Always keep people and objects away from the gate and its area of travel. **NO ONE SHOULD CROSS THE PATH OF A MOVING GATE.**

II. During Installation

1. Install the gate operator on the inside of the property and fence line. **DO NOT** install an operator on the outside of the gate where the public has access to it.
2. Be careful with moving parts and avoid close proximity to areas where fingers or hands could be pinched.
3. **Devices such as contact sensors (safety edges) and non contact sensors (photo beams R4222) provide additional protection against entrapment.** (see accessories on page 26)
4. If push buttons or keypads are installed, they should be within sight of the gate, yet located at least 10 feet from any moving part of the gate. **Never install any control device where a user will be tempted to reach through the gate to activate the gate operator.**
5. Do not activate your gate operator unless you can see it and can determine that its area of travel is clear of people, pets, or other obstructions. Watch the gate through its entire movement.
6. Secure outdoor or easily accessed gate operator controls in order to prohibit unauthorized use of the gate.

IMPORTANT SAFETY INSTRUCTIONS



III. After Installation

1. Attach the **warning signs** (*included*) to each side of the gate to alert the public of automatic gate operation. It is **your responsibility** to post warning signs on both sides of your gate. If any of these signs or warning decals become damaged, illegible or missing, replace them immediately. Contact GTO for free replacements.
2. The gate is automatic and could move at any time, posing a serious risk of entrapment. No one should be in contact with an activated gate when it is moving or stationary.
3. Do not attempt to drive into the gate area while the gate is moving; wait until the gate comes to a complete stop.
4. Do not attempt to “beat the gate” (drive through) while the gate is closing. This is extremely dangerous.
5. Do not allow children or pets near your gate. **Never let children operate or play with gate controls.** Keep ALL gate controls away from children and unauthorized users; store controls where children and unauthorized users do not have access to them.
6. **KEEP GATE AND GATE Operator PROPERLY MAINTAINED.** Always turn power to operator OFF before performing any maintenance. Regularly lubricate rollers.
7. To operate this equipment safely, YOU must know how to disconnect the operator for manual gate operation (page iii). If you have read the instructions and still do not understand how to disconnect the operator, contact the GTO Service Department.
8. Disconnect the operator **ONLY** when the power is **TURNED OFF** and the gate is **NOT** moving.
9. Make arrangements with local fire and law enforcement for emergency access.
10. Distribute and discuss copies of the **IMPORTANT SAFETY INSTRUCTIONS** section of this manual with all persons authorized to use your gate.
11. **IMPORTANT: Save these safety instructions. Make sure everyone who is using or will be around the gate and gate operator are aware of the dangers associated with automated gates. In the event you sell the property with the gate operator or sell the gate operator, provide a copy of these safety instructions to the new owner.**

Should you lose or misplace this manual, a copy can be obtained by downloading one from the GTO web site (www.gtoaccess.com), by contacting GTO Access Systems, LLC., at 3121 Hartsfield Road, Tallahassee, Florida 32303 or by calling 1-800-543-4283 and requesting a duplicate copy. One will be provided to you free of charge.

Required Safety Precautions for Gates

Install Warning Signs

Warning signs alert people of automatic gate operation and are **required** when installing the GTO Gate Operator. The Warning Signs included must be installed on both sides of each gate. Furthermore, a walk-through gate must be installed for pedestrian traffic.

Entrapment Protection

Dual Sense Technology™ provides entrapment protection, when properly adjusted. Since all installations are different, you may need to add photo beams or sensing edges to help prevent damage to vehicle or other items that could be hit by a moving gate.



IMPORTANT SAFETY INSTRUCTIONS

Secondary Means of Protection Against Entrapment

The gate operators utilize Dual Sense Technology™ entrapment protection. Dual Sense Technology™ is built into every operator and provides redundant methods of entrapment protection for open and close gate directions.

In addition to Dual Sense Technology, every operator controller has provisions for the connection of additional obstruction detection devices such as sensing edges and photo beams.

Since all installations are different, you may need to add photo beams or sensing edges to help prevent damage to vehicle or other items that could be hit by a moving gate.

These devices may be located where there is an increased risk of obstruction.

One or more edge sensors may be located at the lead-ing edge, bottom edge, and post edge, both inside and outside of a vehicular swing gate system.

Wiring to sensors must be located and arranged so the wiring between the sensor and the gate operator is not subjected to mechanical damage.

A wireless sensor such as one that transmits radio frequency (RF) signals to the gate operator for obstruction protection functions shall be located where the transmission of the signals is not blocked or impeded by building structures, natural landscaping or similar objects.

As specified by Gate Operator Safety Standard, UL 325, vehicular gate operators shall;

Have provisions for, or be supplied with, a minimum of two independent entrapment protection means for each entrapment zone.

Operate only after installation and enabling of the minimum number of acceptable entrapment protection means.

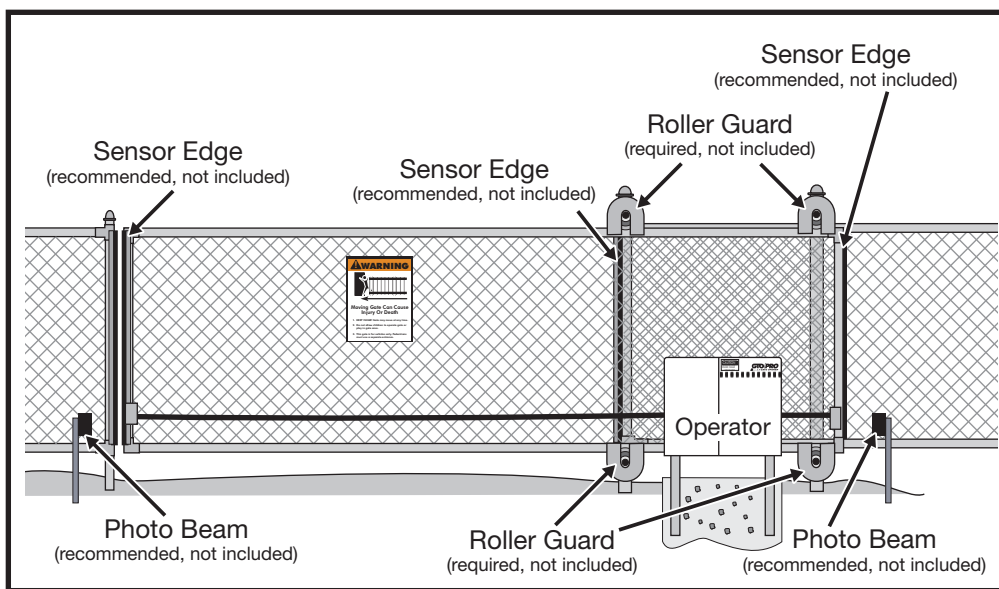

ENTRAPMENT ALARM (UL 325)

The gate operator is designed to stop and reverse within 2 seconds when the gate comes in contact with an obstruction. Additionally, these operators are equipped with an **audio entrapment alarm** which will activate if the unit obstructs **twice** while opening or closing. This alarm will sound for a period of 5 minutes, or until the operator receives an intended signal from a hard wired entry/exit source (e.g. push button control or keypad) and the gate returns to a fully open or fully closed position. Turning the power switch on the control box OFF and back ON will also deactivate the alarm. Wireless controls such as transmitters and wireless keypads will not deactivate the alarm.

IMPORTANT SAFETY INSTRUCTIONS



Install Screen Guard Over Gate and Fence

Injuries may occur when people place their hands, arms, legs, etc., through openings in the gate grill when the gate is operated, trapping them between the grill and the fence post (or fence). All openings of a horizontal slide gate must be guarded or screened from the bottom of the gate to a minimum of 6 feet above the ground to prevent a 2 ¼" diameter sphere from passing through openings anywhere in the gate. This screen/guard must also be installed over the portion of adjacent fence that the gate covers in the open position. Screening will prevent access through openings in areas where the gate may travel.

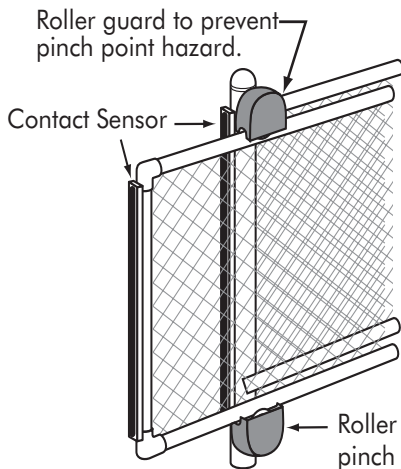
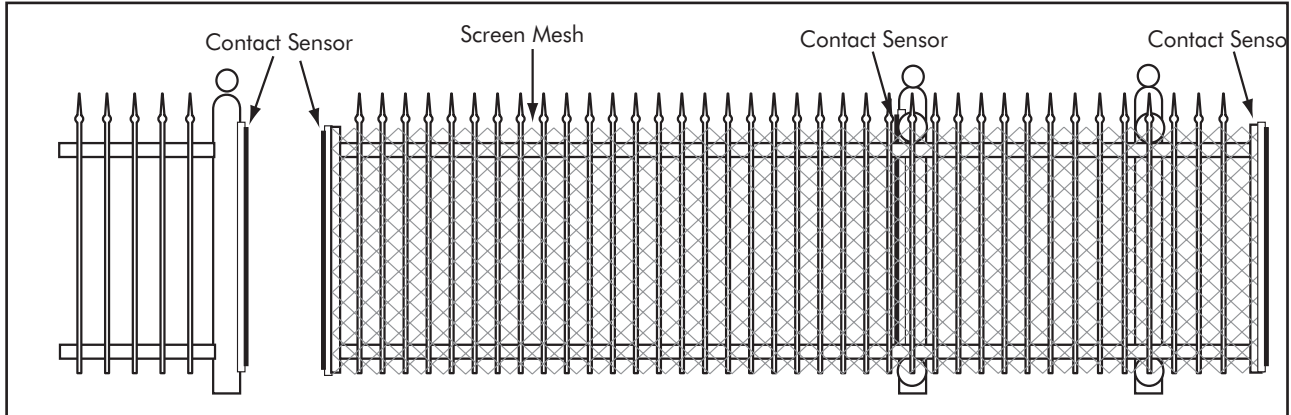

Injuries occur when people get their hands caught between the gate and the roller. Roller guards or enclosed tracks must be installed to prevent this pinch point hazard.



The warning signs (left) must be installed on both sides of the gate.

GTO's internal obstruction settings, even when properly adjusted, may not be sensitive enough to prevent bodily injury. For this reason, safety devices such as safety edges **MUST** be installed. Furthermore, a pedestrian gate must be installed if walk-through traffic is expected near the gate.

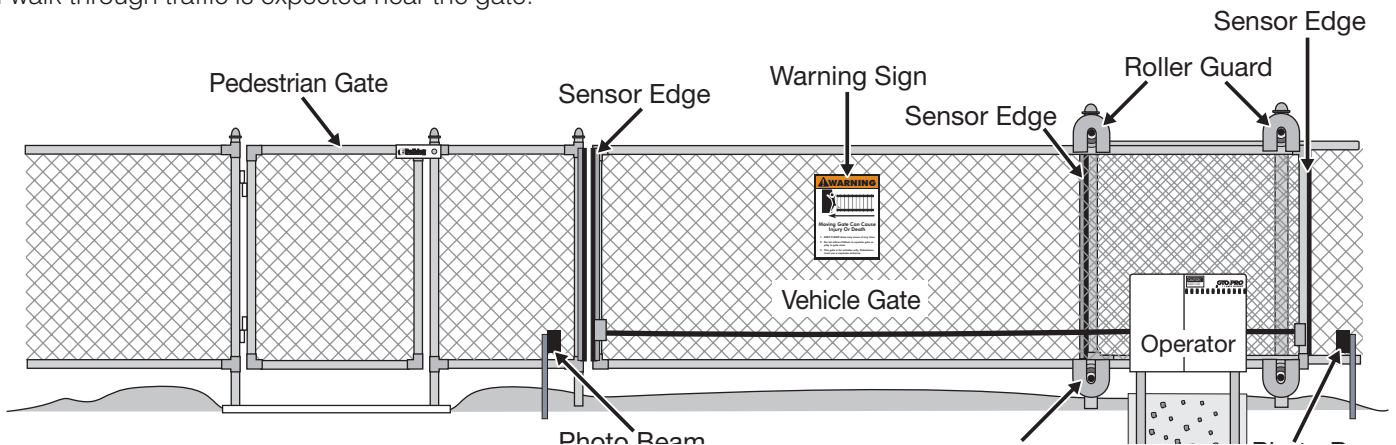



IMPORTANT SAFETY INSTRUCTIONS

These warning labels should be found at the locations specified below. If any of them are missing, immediately contact your installer for replacements.

! WARNING



Moving Gate Can Cause Injury Or Death

1. **KEEP CLEAR! Gate may move at any time.**
2. **Do not allow children to operate gate or play in gate area.**
3. **This gate is for vehicles only. Pedestrians must use a separate entrance.**

warning signs (2) to be installed on each side of the gate (3–5 feet above the bottom of the gate)

! WARNING



- Fingers, hands, and loose clothing may be dragged into chain sprockets.
- Fingers and hands can be injured by rotating sprockets.
- Keep hands, fingers, and loose clothing away from chain and sprockets.

warning label located on top of control box

! WARNING

- Adjusting limit switches with power on will activate gate.
- Injury may result if fingers get caught under switch plate while adjusting switches.
- Use extreme caution when adjusting switches.

warning label located on limit switch plate

! WARNING



- Fingers, hands, and loose clothing may be dragged into chain sprockets.
- Fingers and hands can be injured by rotating sprockets.
- Keep hands, fingers, and loose clothing away from chain and sprockets.

warning sign located (inside housing) over the top sprocket at back of operator

! WARNING



- Fingers, hands, and loose clothing may be dragged into chain sprockets.
- Fingers and hands can be injured by rotating sprockets.
- Keep hands, fingers, and loose clothing away from chain and sprockets.

warning label located (inside housing) next to sprockets on back of operator

! WARNING

- **Moving parts inside are capable of causing injury to fingers and hands.**
- **DO NOT remove operator housing.**
- **Consult your safety manual before making adjustments.**
- **For service, call an experienced technician.**

GTO AUTOMATIC GATE OPENERS 1-800-543-GATE

warning label located on front of operator housing



GTO-SL2000 Series
Conforms to UL 325 STANDARDS
Certified to CAN/CSA-C22.2 No.247-92

Maximum Gate: 1000 lb. (453.4 kg); 30 ft. (9.1 m)
 Voltage: 12 Vdc; Frequency: 0 Hz; Power: 93.2 W
 Class I Vehicular Slide Gate Operator
 Serial Number: **SL2000-xxxxxxx**

Disconnect operator ONLY when the gate is NOT moving.

TO MANUALLY OPEN AND CLOSE THE GATE:

1. Lift quick release pins UP, then pull them OUT of chain brackets.
2. Lay chain down and manually slide gate to desired position.

GTO Access Systems, LLC – Tallahassee, Florida USA RB2002

product identification and manual operation instruction label installed on control box cover

! WARNING



- Fingers, hands, and loose clothing may be dragged into chain sprockets.
- Fingers and hands can be injured by rotating sprockets.
- Keep hands, fingers, and loose clothing away from chain and chain opening in operator housing.

warning labels (3). Located on both sides and back of operator housing

Before You Begin...

1. Determine Charging Option for Battery: Transformer OR Solar

**NEVER USE TRANSFORMER AND SOLAR PANEL(S) AT THE SAME TIME.
It will damage the control board.**

IMPORTANT:

- The operator's 12 volt battery must be charged by either connecting the transformer (included) or solar panel kit ⊕[FM123] to the control board.
- The transformer is designed for indoor use. If the transformer can be plugged only into an outside electrical outlet, a weatherproof cover/housing (available at local electrical supply stores) must be used.
- If your gate is more than 1000 ft. from an AC power source, you will need to use at least 10 watts solar charging power to charge the battery ⊕[FM123]. Refer to the Solar Panel and Gate Activity chart below.
- All low voltage wire used with the GTO Gate Operator must be 16 gauge dual conductor, stranded, direct burial wire ⊕[RB509]. **Do not** run more than 1000 ft. of wire.
- For solar power application, a marine style battery in weather proof housing is recommended (not included).

Solar Panel and Gate Activity Chart

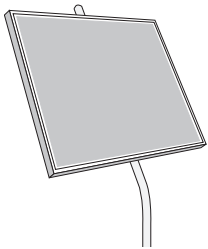

The table and map illustrate the maximum number of gate cycles to expect per day in a particular area when using from 10 to 20 watts of solar charging power. The figures shown are for winter (minimum sunlight).

Accessories connected to your system will draw additional power from the battery.

NOTE: A minimum of 10 watts solar charging power is needed to charge the batteries.

⊕ 10 Watt Solar Panel [FM123]

⊕ 5 Watt Solar Panel [FM122]

Estimated Maximum Number of Cycles Per Day

Winter Ratings	Watts	Zone 1	Zone 2	Zone 3
Single Gate	10	4	8	13
Single Gate	20	8	16	26
Dual Gate	20	4	8	13

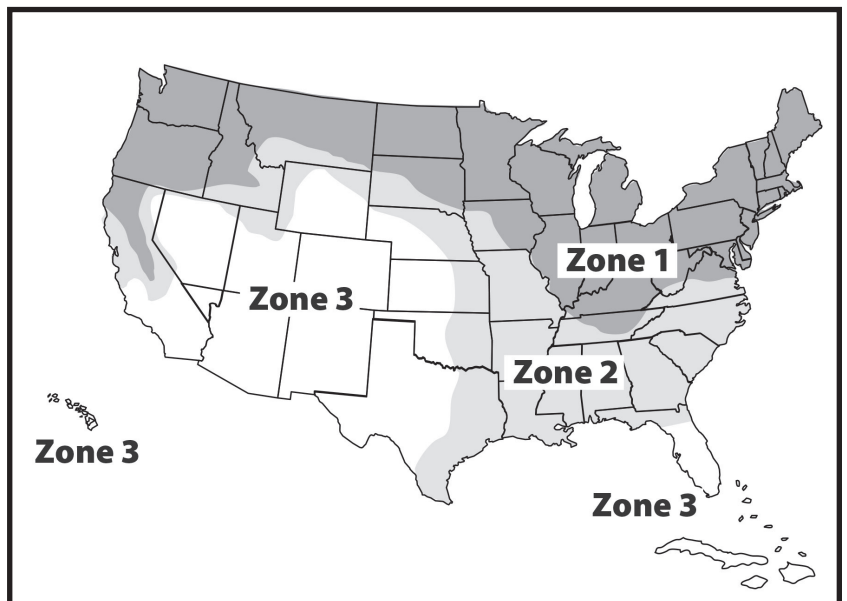

TECHNICAL SPECIFICATIONS

DRIVE

- Powered by a 12 V motor with integral case hardened steel gear reducer. Motor speed reduced to 90 rpm.
- Gate velocity: 1 ft/second.

POWER

- Two blade style fuses rated for 20 A.
NOTE: The transformer should not be connected directly to any battery. Transformer must be connected to the control board with a minimum of 16 gauge, stranded, dual conductor, direct burial low voltage wire. Do not replace fuses with higher ampere rated fuses; doing so will void the warranty and may damage the control board.
- Solar charge maintained by GTO Solar Panel Charger.

CONTROL

- Auto-memorization of digital transmitter code. Charging regulated by circuit on control board. "Sleep draw" is 40 mA; "active draw" is 5 to 13 A.
- GTO remote-mounted RF receiver tuned to 318 MHz.
- Limit controls are mechanical. Normally open contact.
- Adjustable auto-close timer (3 to 120 s), and Dual Sense Technology Stall Force.
- Power terminal block accommodates a transformer and solar panels.
- Operator terminal blocks accommodate safety edges and photoelectric sensors for opening and closing modes.
- Fully compatible accessory terminal block provides connections for safety loops, wands, intercoms, card readers, phone systems, etc.
- Accessory terminal block fully compatible with GTO push button controls, digital keypads, loop detectors, etc.
- Control board allows connection of safety edge sensors and photoelectric sensors.
- Audio entrapment alarm sounds if unit encounters an obstruction twice while opening or closing.

Rollers should be lubricated at least four times per year.

Gate Capacity Chart for SL-2000BE Series <i>(estimated number of cycles based on use with a transformer)</i>					
Gate Opening	20 ft.	80	70	60	50
	16 ft.	100	90	80	70
	12 ft.	120	110	100	90
	8 ft.	140	130	120	110
	400 lb.	600 lb.	800 lb.	1000 lb.	
Gate Weight					

Cycles shown are for single gate, dual gates will get approximately half as many cycles.

Housing Dimensions: Height: 18" Width: 211/2" Depth: 11"

OPERATIONAL CAPACITY

- The operator will handle gates weighing up to 1000 lb. (453.4 kg) and up to 30 ft. (9.14 m) in length (per leaf) if the proper installation procedures have been followed. Note that ball bearing rollers and covers should be used on all gates.
- The operator is capable of high volume cycling; however, the total cycles per day will depend on the motor current and efficiency of the gate installation (see chart above). For questions relating to specific applications and for information regarding cycling duty when charged by solar panels, see page 1. These specifications are subject to change without notice.

PARTS IDENTIFICATION

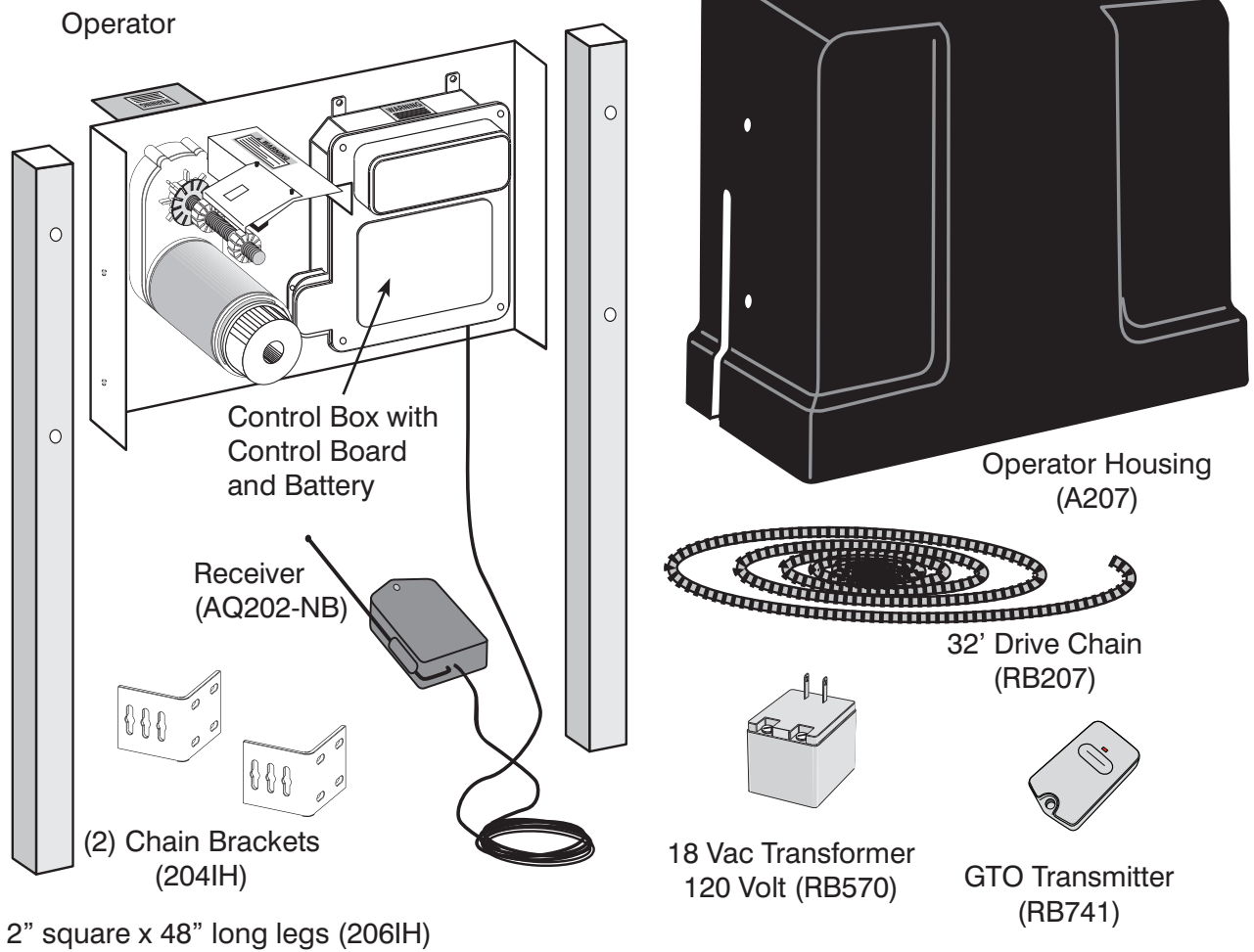

Hardware Bag

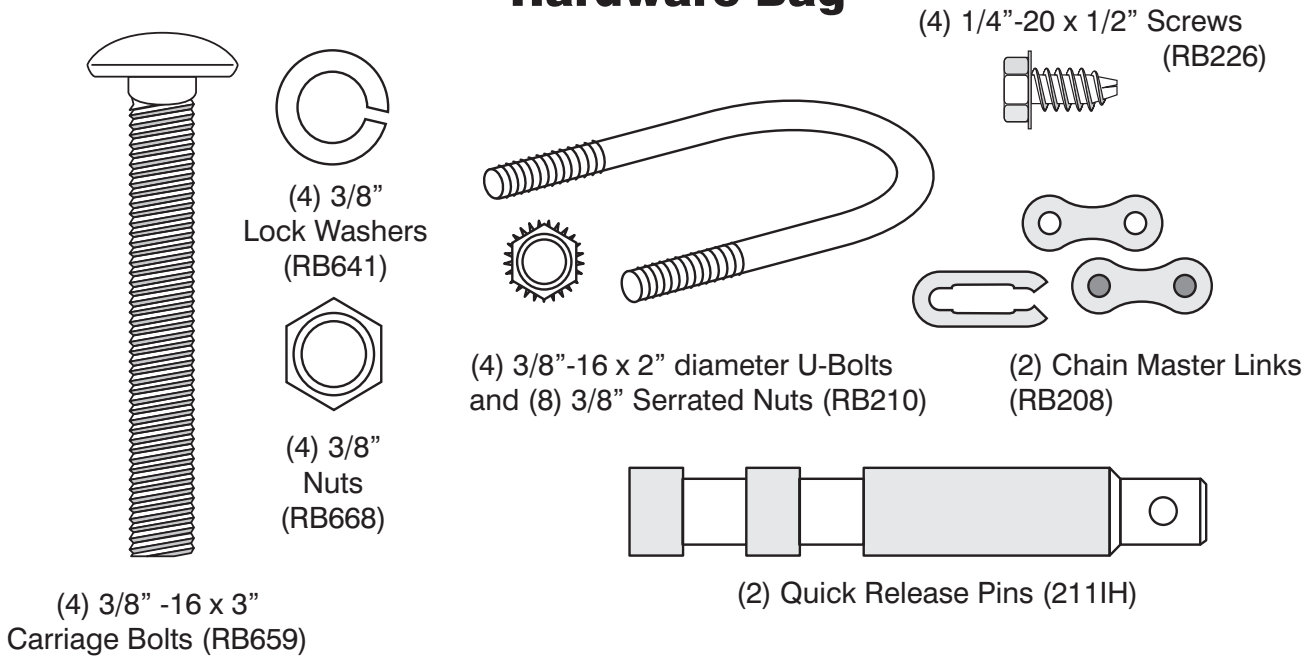

SINGLE GATE OPERATOR INSTALLATION

Gate Preparation

Be sure the gate is properly installed and slides smoothly before installing the Slide Gate Operator. The gate must be plumb, level, and move freely. The gate must not bind or drag on the ground. Never use a wheel on the gate, because the additional drag and resistance can cause the operator to obstruct.

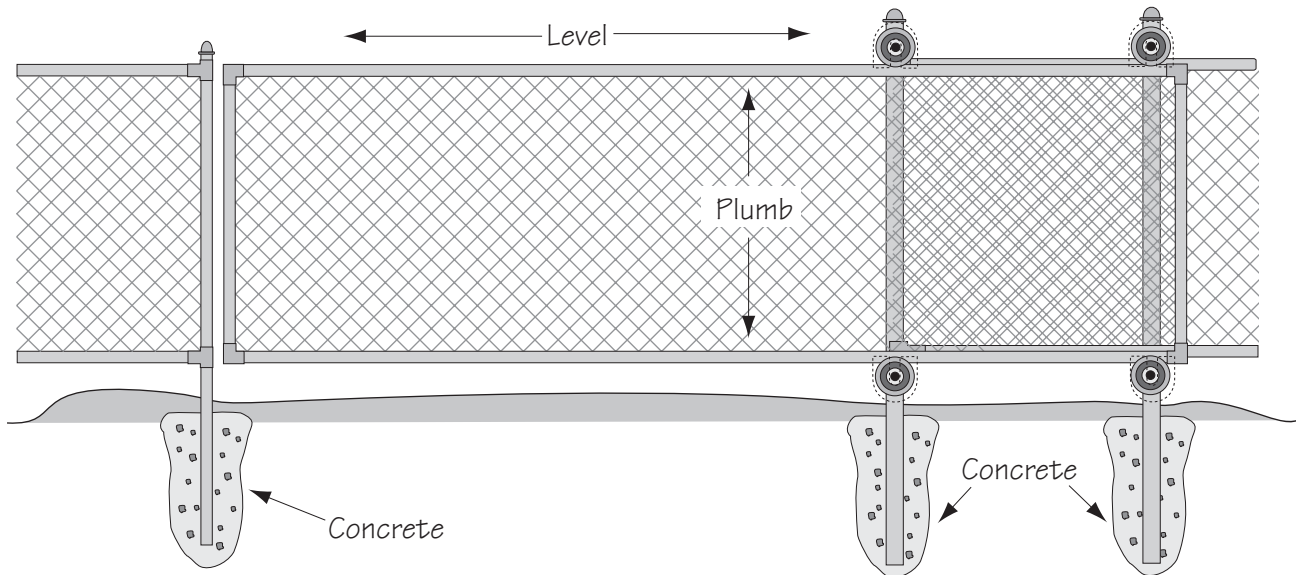

Overview of Operator Installation

The diagram below shows a single slide gate installation with required safety features. The operator must be installed on the inside of the gate. GTO requires using safety edges and roller guards to help reduce the possibility of bodily injury.

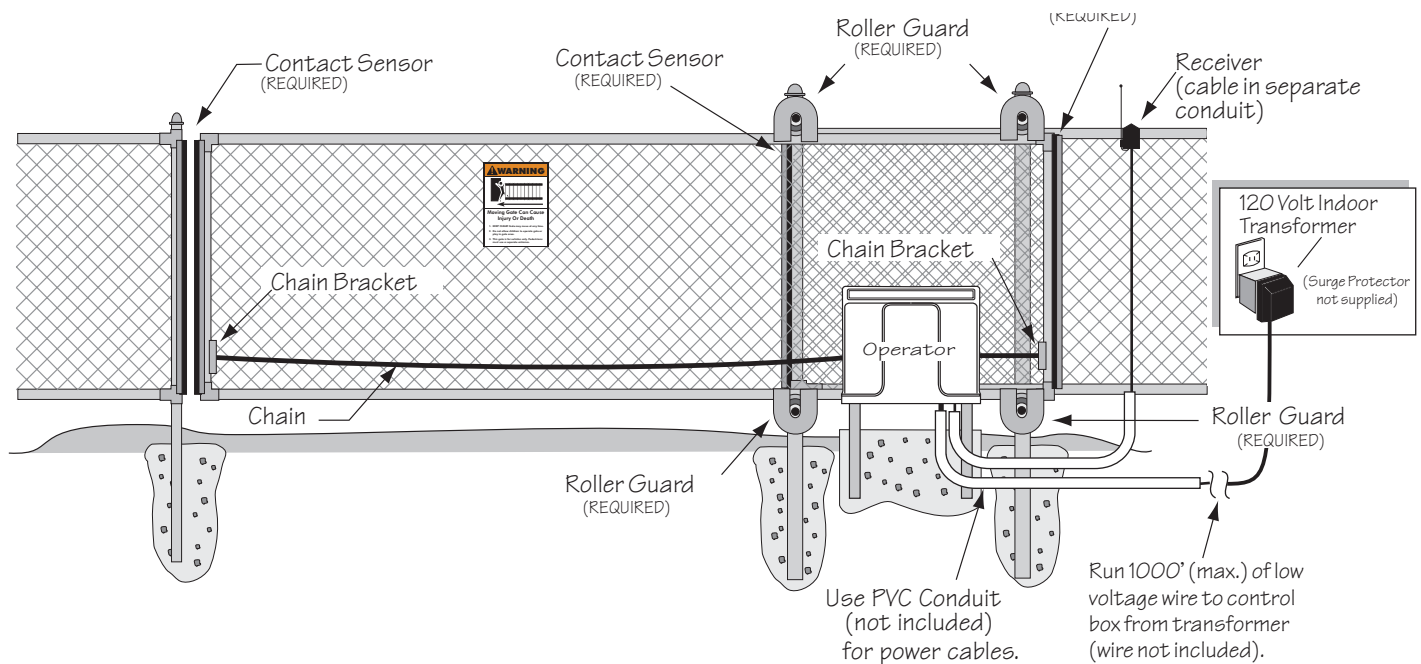

Recommended Wiring and Use of Conduit

Run the low voltage wire and receiver wire through PVC conduit into the slider unit to protect it from damage. PVC conduit should be used for accessory wires such as loop detectors, key pads, card readers or any other entry device.

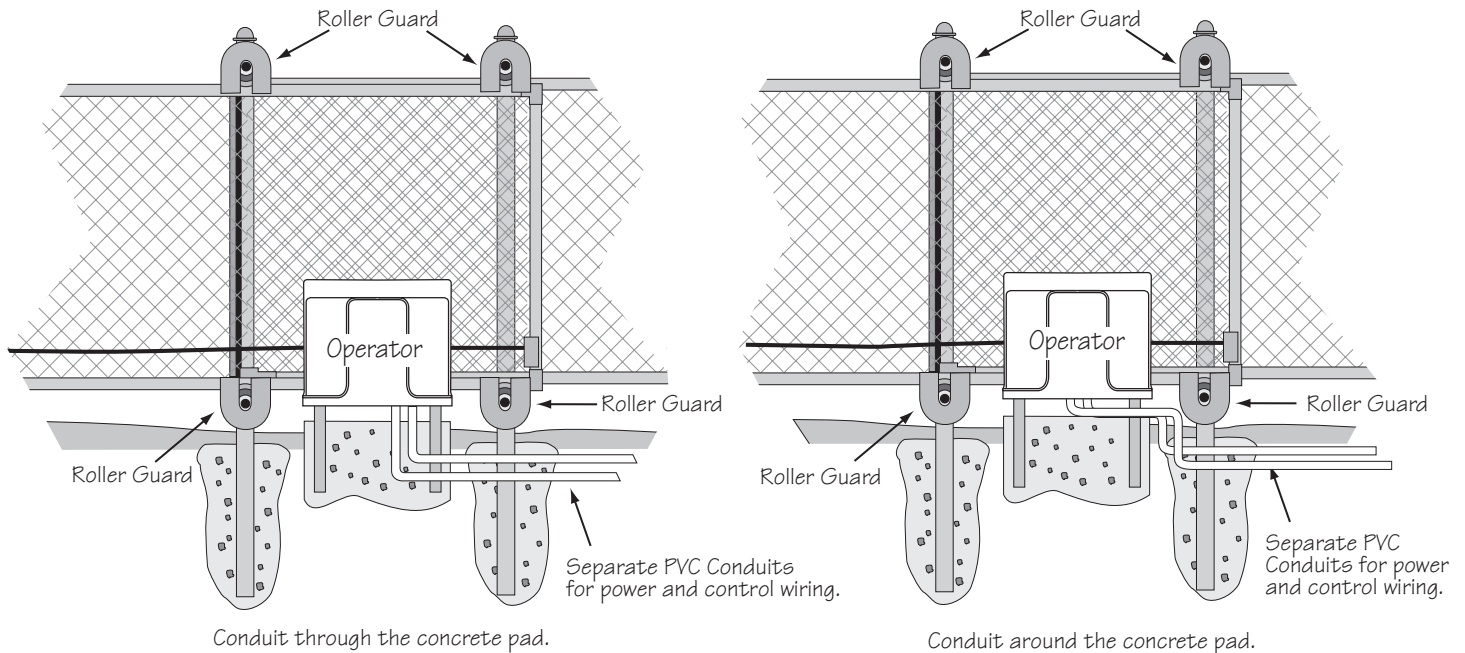

Mounting the Legs on the Gate Operator

Step 1

Mount the legs on the slide gate operator using the 3/8" x 3" Carriage Bolts, 3/8" Flat Washers, 3/8" Lock Washers, and 3/8" Nuts.

See Illustration A.

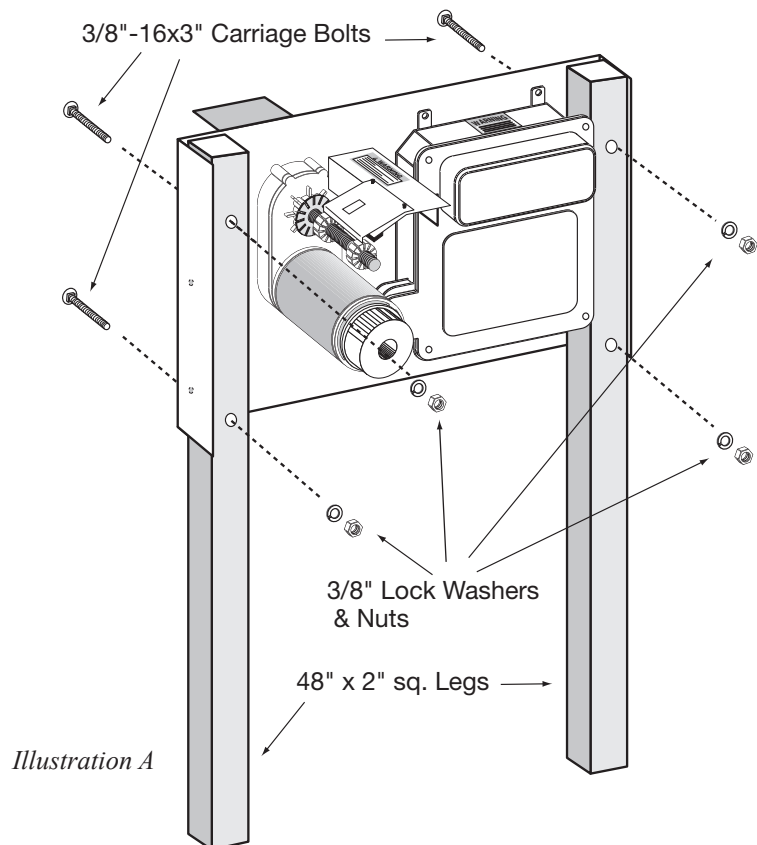

Determining the Mounting Position and Mounting the Operator

Step 2

Install chain brackets at each end of the gate on the inside (operator side) of the gate (see Overview Illustration, page 4). Position the tops of chain brackets no more than 6" above the bottom corners of the gate frame and secure with U-bolts (see Illustration B). The chain brackets will work on gate frames 1³/₄" to 2¹/₂" in diameter or square tube gates. The U-bolts provided will work on 2" diameter pipe. Larger gate sizes will require larger U-bolts.

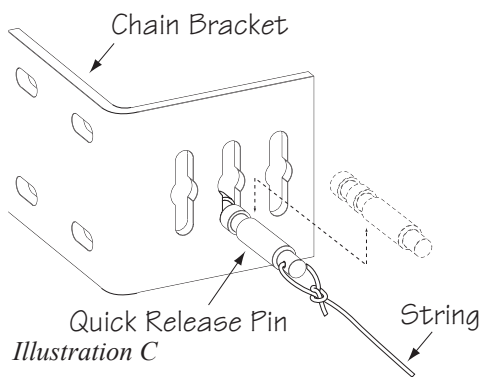

Step 3

Insert a quick release pin into the center slot in each of the chain brackets (see Illustration C). Tie a string to the end of each quick release pin so that the string is tight between the two chain brackets (the string will be used to align the operator). The string should be 7"-10" from the ground (see Illustration E). The chain brackets can be adjusted up or down on the gate to achieve the proper height. The goal here is to set the height of the operator so that when the housing is in place it will clear the ground by 1" to 4" (see Illustration E).

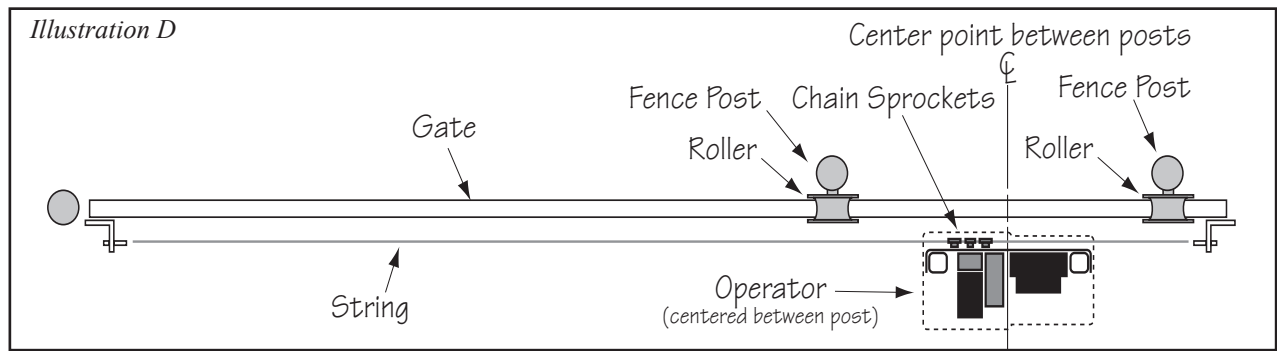
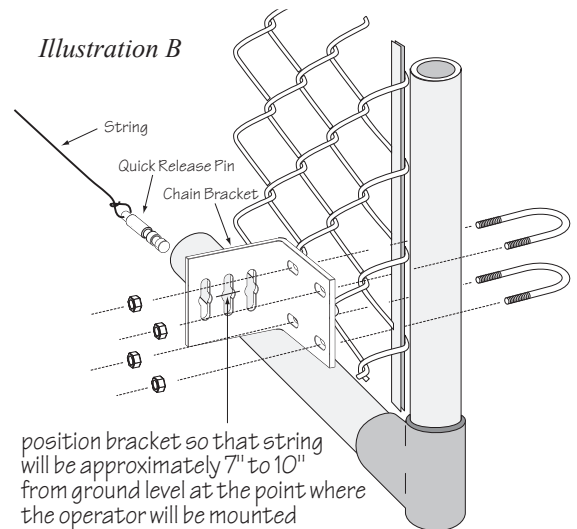

Step 4

Find the center point between the two roller/fence posts (see Illustration D). This should coincide with the position of the center point of the operator. Dig a hole approximately 12" x 28" wide x 28" deep. Place the operator in the hole on its legs and position the bottom idler sprockets on the top of the string and level the unit (see Illustration E). Make sure operator is level and plumb. With the unit level and in place, pour the concrete and let set for 24 hours before proceeding to the next step.

BEFORE POURING CONCRETE: 1] Make sure operator is centered between roller posts and aligned with string; and, 2] Determine method of installing conduit for wiring (see page 5)!

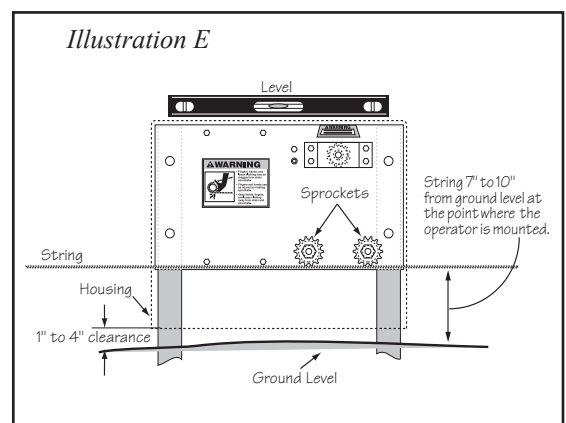

Installing the Chain

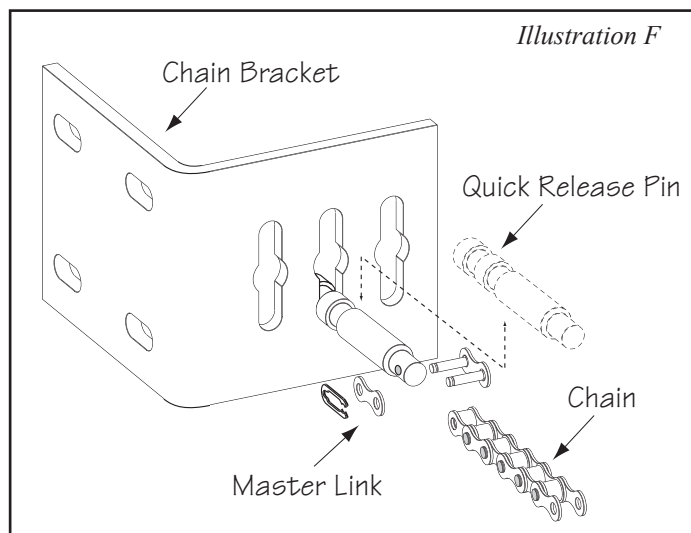

Step 5

After the concrete has hardened, remove the string from the quick release pins. Attach the chain to one quick release pin with a master link (see *Illustration F*). Run the chain through the chain sprockets (see *Illustration G*).

Step 6

Pull the chain to the second chain bracket. (see *Illustration*). Adjust chain to allow 1 inch of slack for every 10 ft. of chain (See *illustration G*). Mark the chain where it meets the second quick release pin.

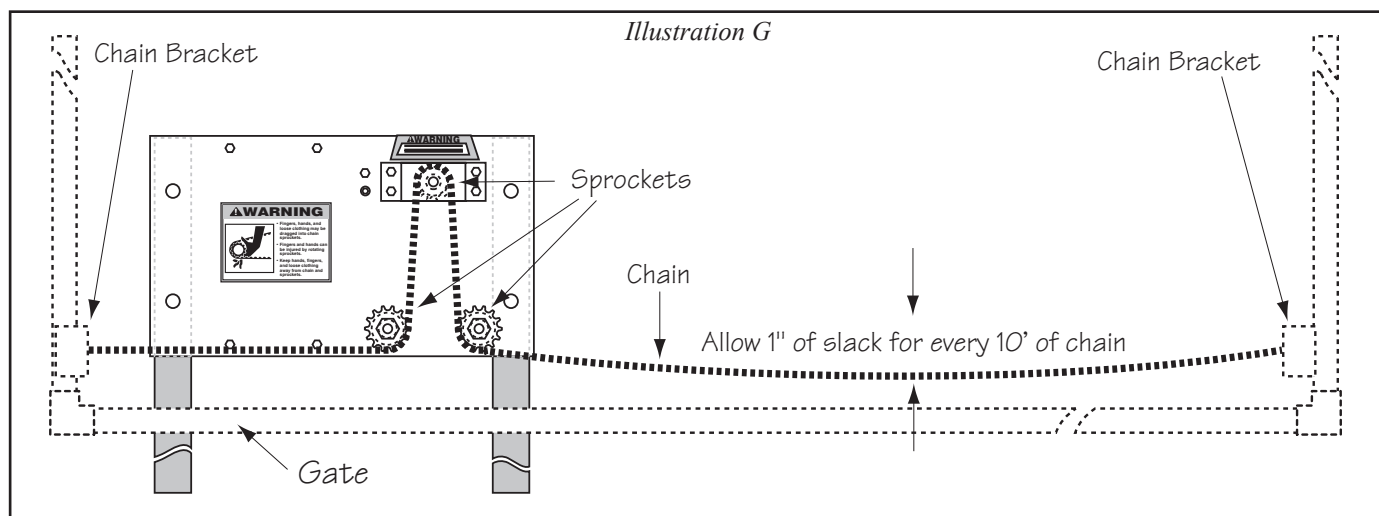

Step 7

Shorten chain by driving the pin out of the chain link using a tool such as a punch or chain break. Connect the chain to the second quick release pin using a master link (See *Illustration H*) to determine the correct length for the chain.

TO OPEN THE GATE MANUALLY:

1. LIFT the quick release pins UP, then PULL them OUT of the chain brackets (see *illustration*).
2. Lay the chain down and manually slide the gate to the desired position.

To prevent unauthorized removal of the quick release pins, install pin locks (see *accessory catalog*) above the quick release pins in both chain brackets.

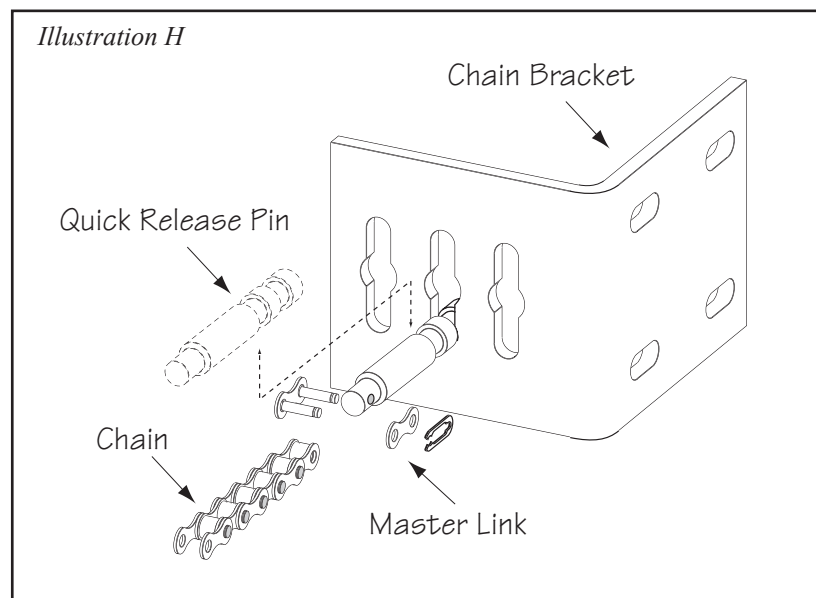

POWERING THE SYSTEM

Connecting the Battery

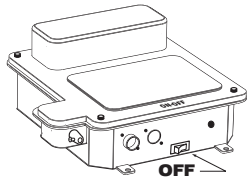

Step 1
Make sure the control box power switch is in the **OFF** position.

Unscrew and remove the front cover of the control box and slide battery into position with its terminals to the left (see illustration). Make sure the battery fits snugly in control box.

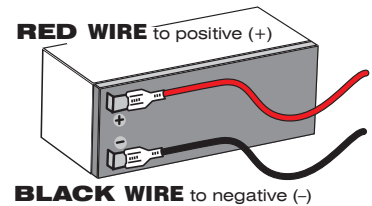

Connect the **black** battery lead to the **negative** (-) terminal, and the **red** battery lead to the **positive** (+) terminal. **DO NOT** allow battery leads to touch the control board! Touching the control board with battery leads can short circuit the system!

Installation of the GTO Transformer. *If using solar go to page 9*

Choose the electrical outlet into which the transformer will be plugged. Measure the distance from the electrical outlet to the control box, following the path where the low voltage wire will run (**the maximum distance can be no more than 1000 ft.**)

Step 2

Run the low voltage wire from the electrical outlet to the control box. **Do not exceed 1000 ft..**

NOTE: Pull approximately 1 ft. of low voltage wire into the control box to accommodate terminal connections. To maintain adequate charging power, use *appropriate gauge, stranded, direct burial wire* (see *Accessory Catalog*).

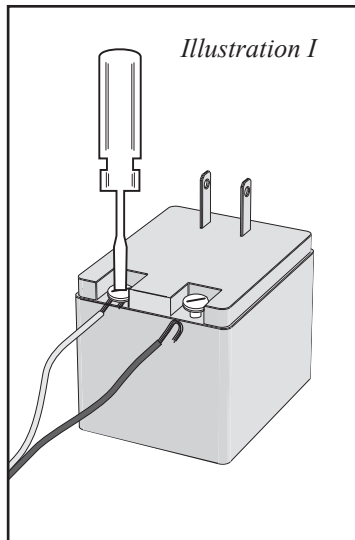

Step 3

Strip $\frac{3}{16}$ " off the ends of the low voltage wire and attach ends to the transformer terminals.

To prevent damage to transformer, make sure the exposed wire ends do not touch each other!

NOTE: Wires coming from the ground to the control box should be run through PVC conduit to protect them from damage.

Feed the low voltage wires upward through the strain relief on the bottom of the control box (see *Illustration J*).

Step 4

Strip $\frac{3}{16}$ " off the ends of the low voltage wire and twist tightly. These wire ends will be attached to the control board at the **18VAC** terminals located on the **POWER IN** terminal block (see *Illustration L*). Wire sheathing should not come in contact with terminals, however, it should not be stripped so far that wires can come in contact with one another (see *Illustration K* or page 9).

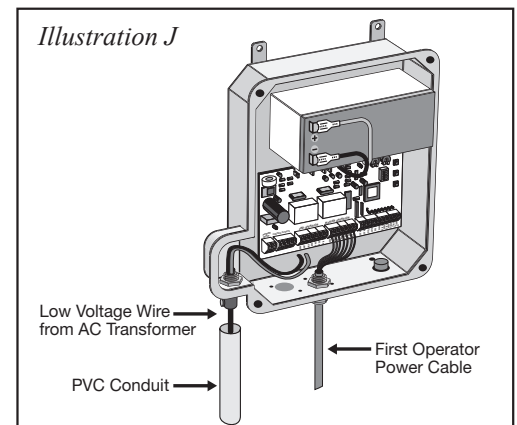

Insert one transformer wire into an **18VAC** terminal. Insert the other transformer wire into the remaining **18VAC** terminal (see illustration L). Transformer wires can be connected to the **18VAC** terminals regardless of color.

Step 5

Plug the transformer into a weatherproof electrical outlet. Check to see if the green LED on the control board is on.

NOTE: Use of a surge protector is strongly recommended.

HINT: Keep a few mothballs in the control box to discourage insects from entering it and damaging the control board.

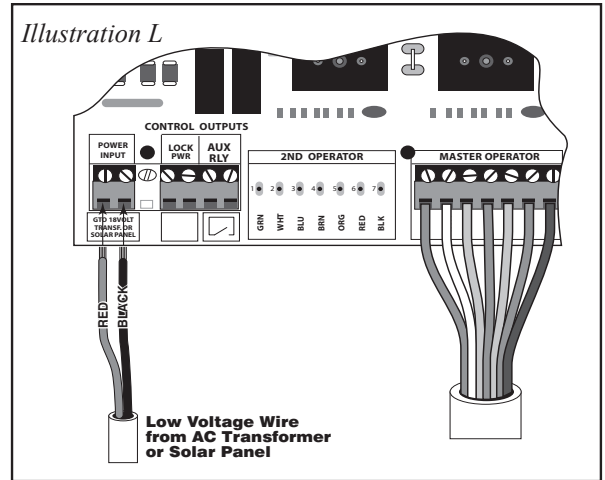
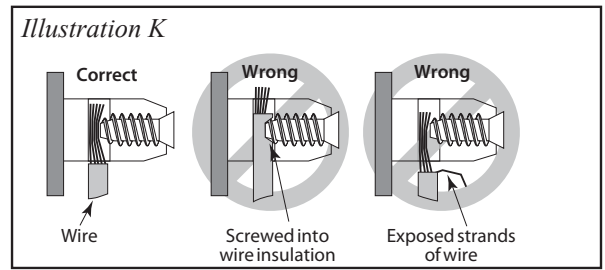
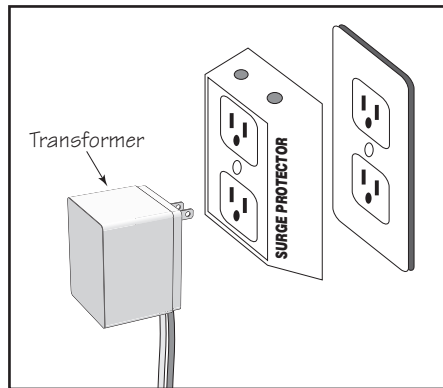

Connecting Solar Panel(s) (Only if transformer is not used)

Step 6

NOTE: NEVER USE THE SOLAR PANEL AND THE AC TRANSFORMER AT THE SAME TIME! It will damage the control board.

Feed the free end of the solar panel wires into the control box and attach them to the appropriate terminals on the control board (see illustration L). The **RED** solar panel wire goes to the (+) **POSITIVE** solar terminal and the **BLACK** solar panel wire goes to the (-) **NEGATIVE** solar terminal.

Tighten set screws against exposed end of wires.

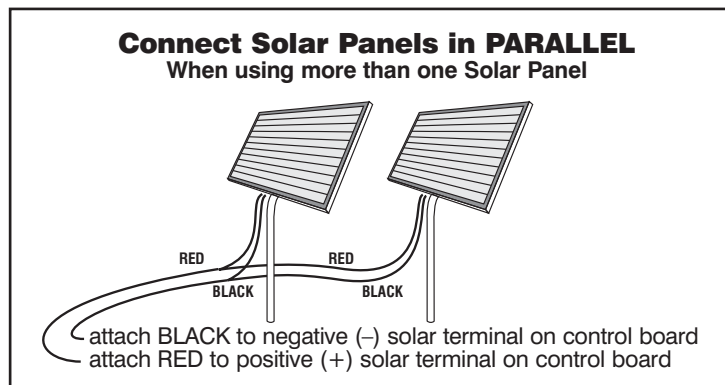

CONTROL BOARD SETTINGS

DIP Switches

The four DIP switches on the control board match the operator with the type of gate on which it is mounted. For example, gates may open right to left or left to right. Prior to packaging, the control board was configured for a single slide gate that opens **right to left** as viewed from inside of the property. If your gate type matches this configuration, you **DO NOT** need to adjust the DIP switches. Proceed to the **Potentiometers** section on the next page.

NOTE: To change the DIP switch settings, you must turn the control box power switch OFF; move the switch; then turn the power back ON. Use a small screwdriver to move the switches.

PULL/PUSH: Set to **PULL** for slide gates that open **RIGHT** to **LEFT** [factory setting]; **PUSH** for slide gates that open **LEFT** to **RIGHT**.

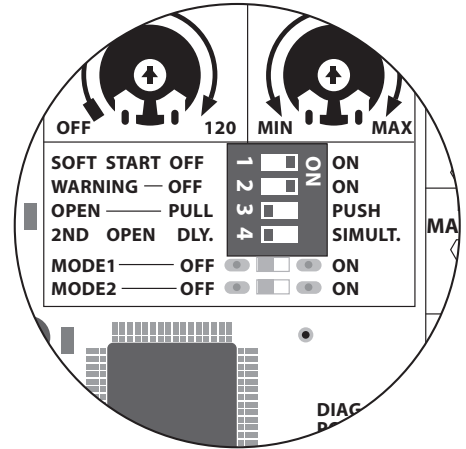

Setting Dual Sense Detection

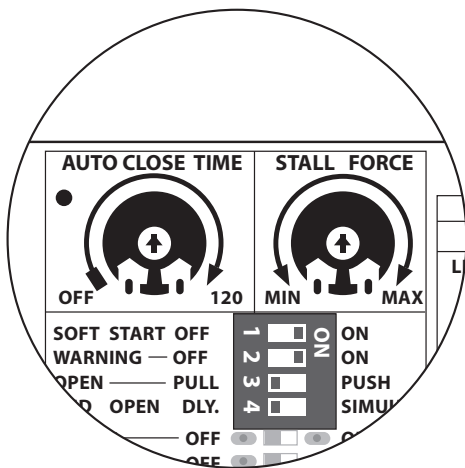

Do not use the Dual Sense Stall Force adjustment to compensate for a gate that is sticking or binding. Excessive Stall Force may cause damage to the gate operator or gate system or Injury or Death.

The Stall Force adjustment controls the amount of force the opener will apply against an obstruction before it stops and reverses direction. The adjustment on the control board operates like a volume control on a radio. It controls the amount of force the opener will apply to an obstruction before it automatically reverses direction.

The Stall Force adjustment is located on the control board. Turn the "STALL FORCE" arrow in the center of the potentiometer with small flat head screwdriver. Adjust the sensitivity from the MINIMUM position up to the point where the gate operates without obstructing from its own weight or the wind conditions in your area.

NOTE: You may need to increase the stall force in cold weather due to increased resistance from gate rollers, sprockets and chain. However, the adjustment must remain as near to minimum as possible and when the weather improves decrease the setting to the appropriate position.

CAUTION

For safety reason the Dual Sense Stall Force setting on the Mighty Mule control board comes from the factory set at MIN (minimum). This setting may need adjustment depending on the size and weight of the gate.
ALWAYS KEEP SAFETY AT THE TOP OF YOUR LIST WHEN ADJUSTING OR SERVICING YOUR GATE SYSTEM.

Program Your Personal Transmitter Setting

Program Your Personal Transmitter Setting

All GTO transmitters are set to a standard code at the factory and are ready to operate your GTO gate operator. For your safety and security, **we strongly recommend** that you replace the factory setting with your own personal setting. Follow the directions below:

NOTE: If you have multiple transmitters, you should adjust all of them at this time. ⚡ [RB741/RB742/RB743].

Step 1

Use a small phillips head screw driver to remove the transmitter cover.

Step 2

Set the transmitter DIP switches using a small screwdriver. There are nine (9) switches; each can be placed in three different positions (+, 0, -). **DO NOT** set all the switches in the same position, such as all +, all 0, or all -. Once the DIP switches have been reset, replace and close the access cover.

WARNING: No other adjustments should be made inside the transmitter.

Step 3

With the control box open locate the **LEARN RMT** button on the control board.

- Press and hold transmitter button.
- Press and hold the **LEARN RMT** (Learn Remote) button on the control board until the alarm sounds.
- Release transmitter and **LEARN RMT** buttons. The new code is stored in control board memory.

NOTE: All transmitters with the same DIP switch settings will now open the gate.



The Troubleshooting Wizard has detailed information about this and other Installations.

24/7 Troubleshooting Wizard: <http://support.gtoinc.com>

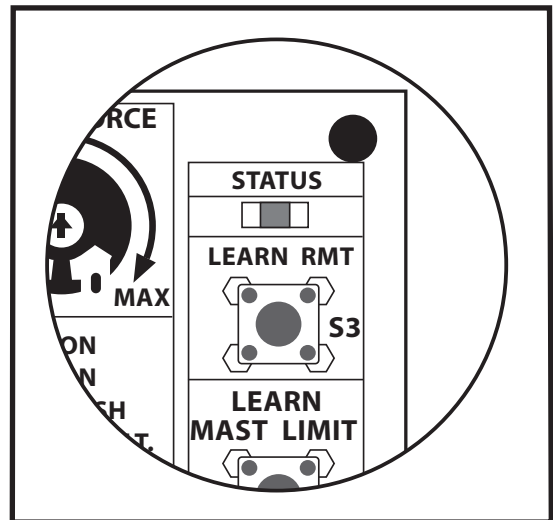
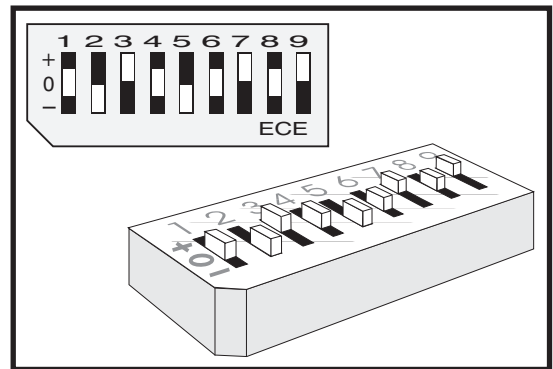
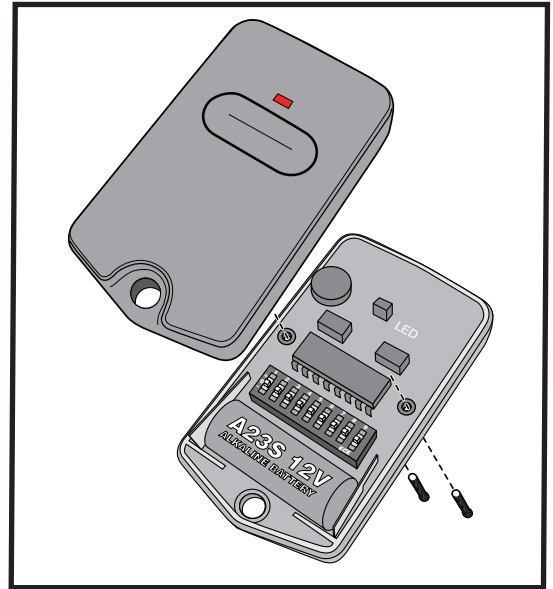

MOUNTING THE RECEIVER

Receiver Installation

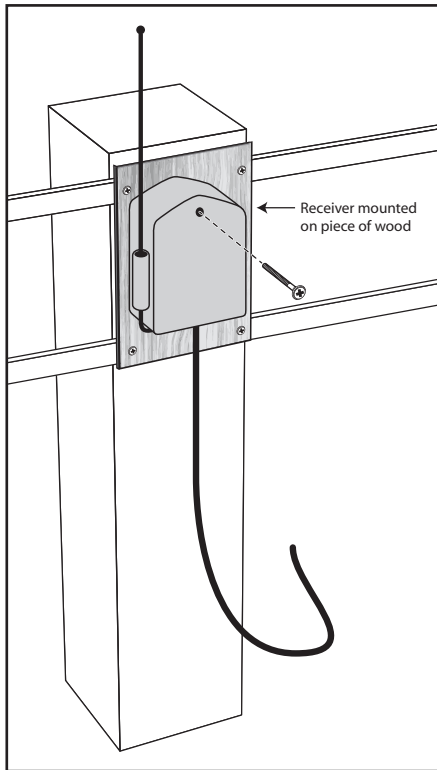

Check the range of the receiver *before permanently mounting* it. You may have to try different locations before permanently mounting the receiver. The receiver range can vary from 50 to 100 feet depending upon weather, topography, and external interference.

Mount the receiver:

- Ensuring a line-of-sight between transmitter and antenna.
- At least 3 feet away from AC voltage.
- As high as possible for optimum range.
- DO NOT mount receiver upside down.
- DO NOT mount receiver on metal fence or post (this will decrease signal range). If attaching receiver to metal fence, you should mount receiver on a piece of wood attached to the fence (see illustration).
- Make sure antenna is higher than other metal objects.

The receiver cable:

- Cable length is 20 ft. (receivers with longer cables are available as special order items; call the GTO Sales Department).
- NEVER splice receiver cable!
- Run the receiver cable through PVC conduit to protect it from damage.
- DO NOT run cable in conduit containing AC wiring.

This device complies with FCC rules Part 15. Operation is subject to the following conditions:

1. This device may not cause harmful interference.
2. This device must accept an interference that may cause undesired operation.

Transmitter distance may vary due to circumstances beyond our control.

NOTE: The manufacturer is not responsible for any radio or TV interference caused by unauthorized modifications to this equipment. Such modifications could void the user's authority to operate the equipment.

ADJUSTING THE LIMIT SWITCHES

After the operator is installed, adjust the open and closed position limit switches as needed. The limit switches determine how far the gate travels to open and to close.

Adjust the limit switches using the limit nuts. Lift limit switch plate to adjust limit nuts (see *Illustration M*).

The open and closed position switches will be reversed depending on whether the gate opens from left to right or from right to left (see *Illustration N*).

⚠ WARNING! USE EXTREME CAUTION when adjusting limit switches to prevent fingers, hair, clothing, etc., from getting caught under the limit switch plate and possibly causing bodily injury.

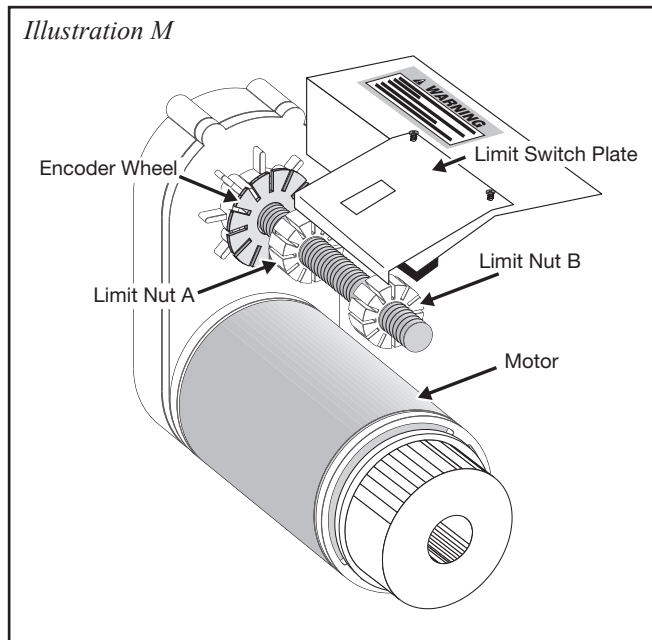

If your gate opens from Right to Left:

1. Gate Opening: For gate to open further, turn Limit Nut A counter clockwise. For gate to open less, turn Limit Nut A clockwise.
2. Gate Closing: For gate to close further, turn Limit Nut B clockwise. For gate to close less, turn Limit Nut B counter clockwise.

If your gate opens from Left to Right:

1. Gate Opening: For gate to open further, turn Limit Nut B clockwise. For gate to open less, turn Limit Nut B counter clockwise.
2. Gate Closing: For gate to close further, turn Limit Nut A counterclockwise. For gate to close less, turn Limit Nut A clockwise.

Once the limit switches are adjusted, make sure the limit switch plate rests in the grooves on both limit nuts.

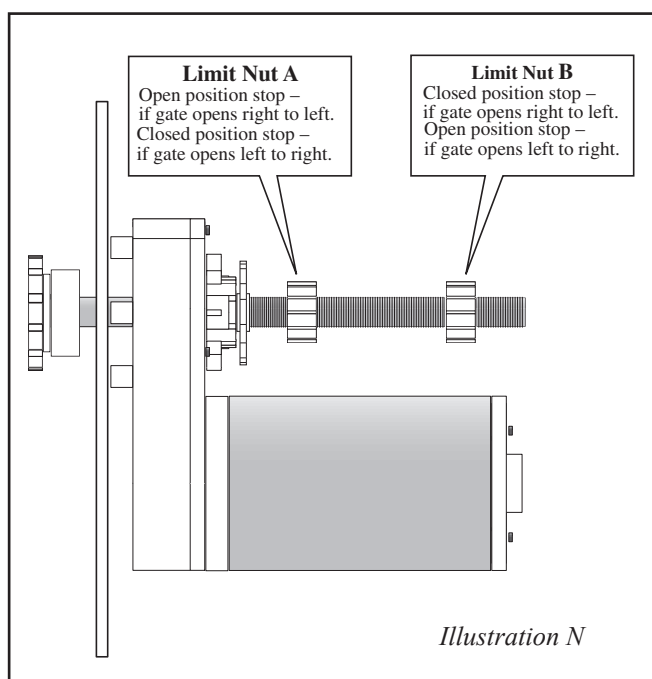
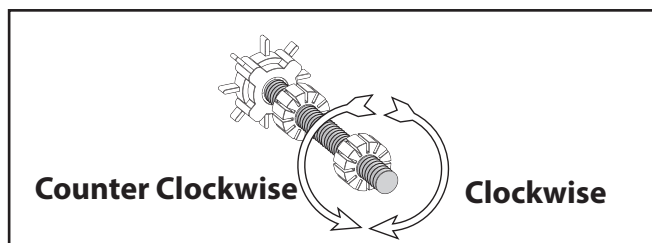

CONNECTING SAFETY DEVICES

The operators are equipped with built-in obstruction detection. These operators are designed to stop and reverse the gate for 2 seconds when it comes in contact with an obstruction.

Photo beams and safety edges are suggested as additional means of safety.

Refer to the sensor manufacturer's instructions for information about installing these devices on a vehicular gate.

⚠ Make sure the control box power switch is OFF before connecting safety device wiring to the terminal blocks.

Insert the Close safety device wires into the **CLOSED EDGE** and **COM** terminals for the gate closing mode. Connect the Open safety device wires into the **OPEN EDGE** and **COMMON** terminals for the gate opening mode.

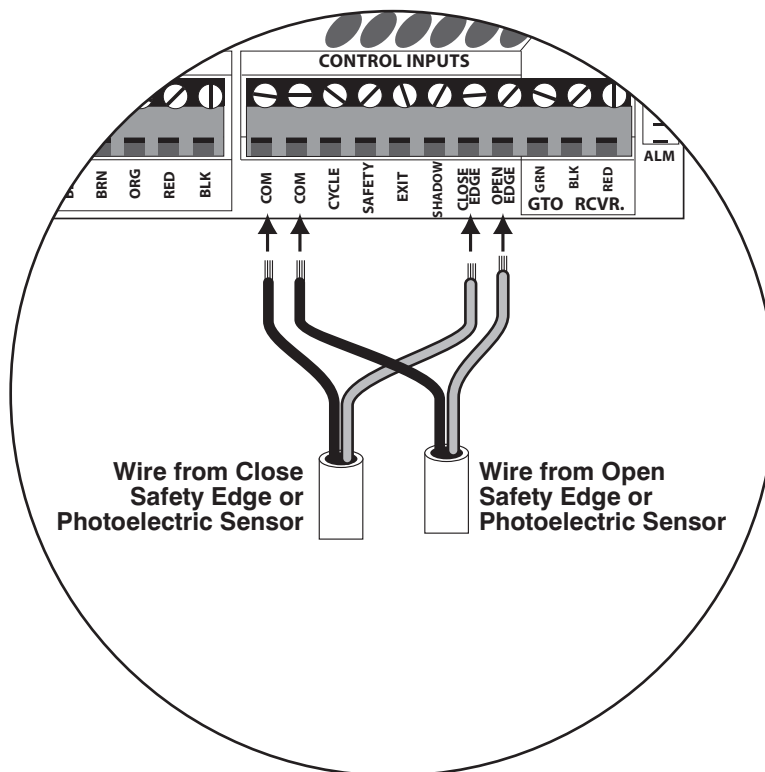

INPUT CONNECTIONS

All inputs are dry-contact, normally open.

- ① **CYCLE:** (Typically used with doorbell button or hard wired key pad)
 - Each activation at this input will cycle the operation as follows ... X Open X STOP X CLOSE X STOP X OPEN X ...
- ② **SAFETY:** (Typically used with photo beam devices, loop detectors or other non-contact sensors)
 - Activation of this input while the gate is closing will cause the gate to stop and return to the open position
 - Activation of this input while gate is opening has no effect (gate will continue to open). *Autoclose will reset.*
 - Activation of this input while gate is idle will prevent gate from closing.
- ③ **EXIT:** (Typically for use with exit loop or wand)
 - Activation of this input will open the gate if it's not already at the open position.
 - Activation of this input while gate is at the open limit will restart the auto close time (if enabled).
- ④ **CLOSE EDGE:** (Typically for use with edge sensor)
 - Activation of this input while the gate is closing will cause the gate to stop and reverse direction for approximately 2 seconds.
 - Activation of this input while gate is opening has no effect (gate will continue to open).
 - Activation of this input while gate is idle will prevent gate from closing.
- ⑤ **OPEN EDGE:** (Typically for use with edge sensor)
 - Activation of this input while the gate is opening will cause the gate to stop and reverse direction for approximately 2 seconds.
 - Activation of this input while gate is closing has no effect (gate will continue to close).
 - Activation of this input while gate is idle will prevent gate from opening.

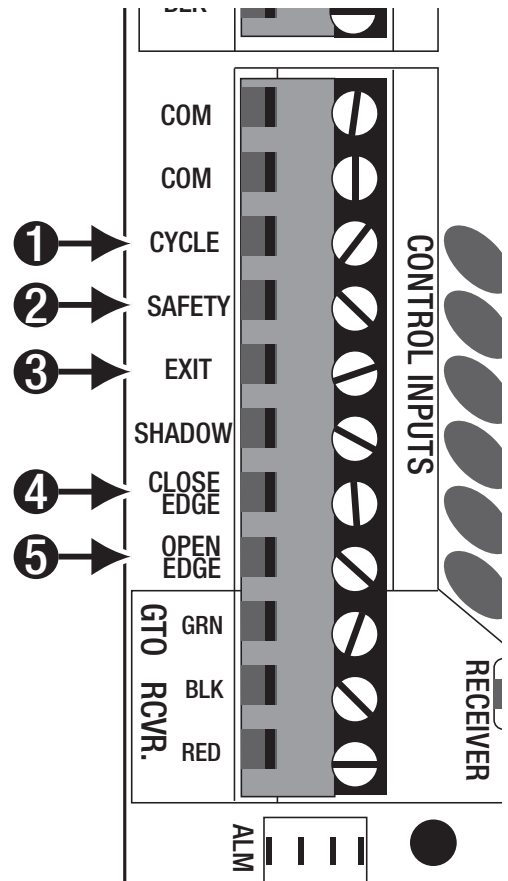

CONNECTING ACCESSORIES

Make sure the control box power switch is OFF before connecting accessories.

The **CONTROL INPUTS** terminal block is the connection point for accessories such as push buttons, safety loops, intercoms, etc. The **CONTROL INPUTS** terminal marked **COM** is the common ground for all accessories. **COM** is paired with the terminals shown below when connecting accessories to the control board.

IMPORTANT: Make sure to twist exposed wires tightly and insert them into the terminals without loose strands. Tighten set screws against exposed end of wires.

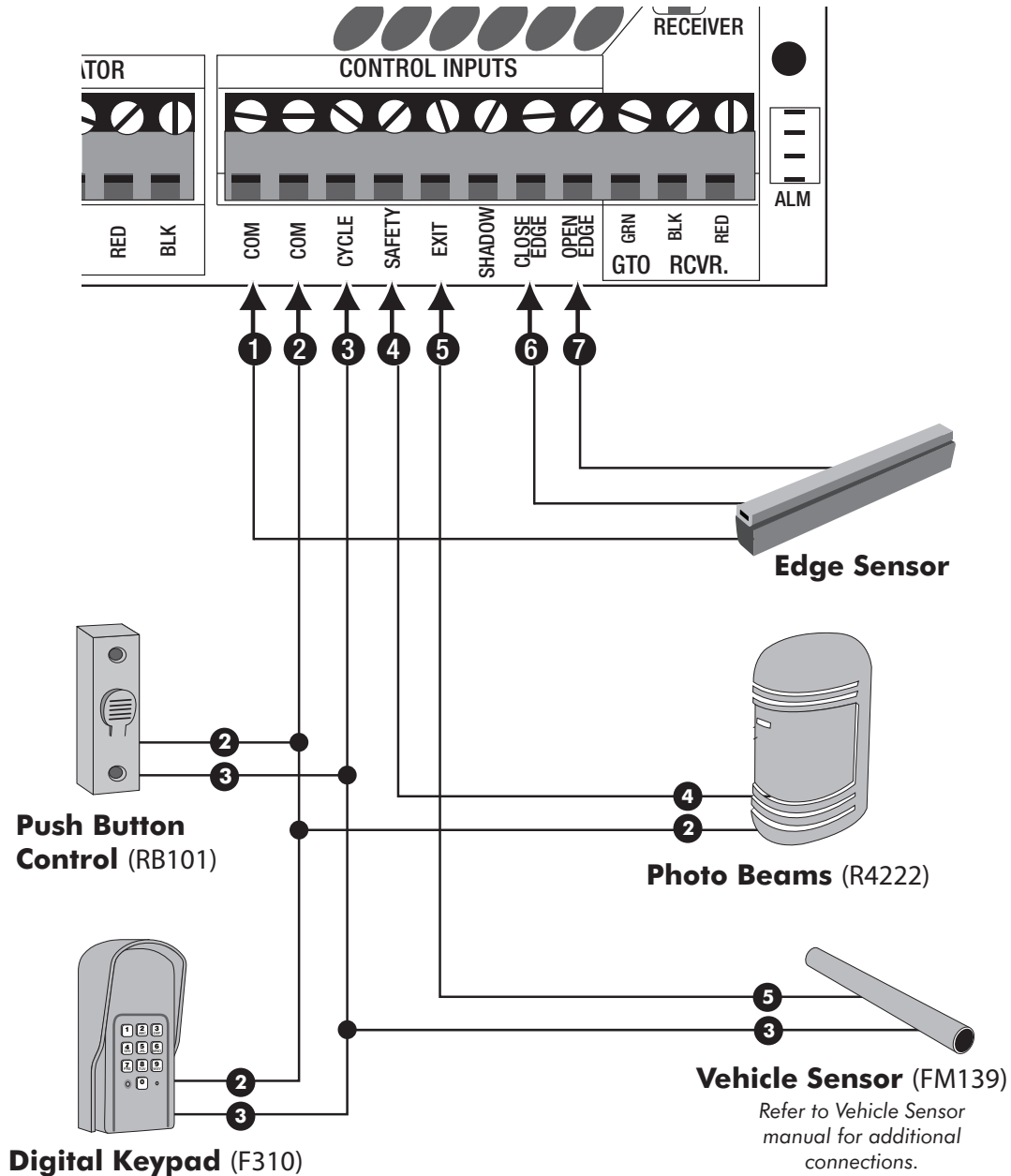

NOTE: There may be additional connection options for applications that are not illustrated here. Refer to accessory manuals for details.

ATTACHING THE HOUSING

Mount the operator housing after all installation procedures are complete. Slide operator housing over legs, align holes, and use screws provided to attach housing to operator.

IMPORTANT: Hang the two (2) GTO Warning Signs (provided) on both sides of the gate before operating. **Make sure** all warning signs and labels are in place.

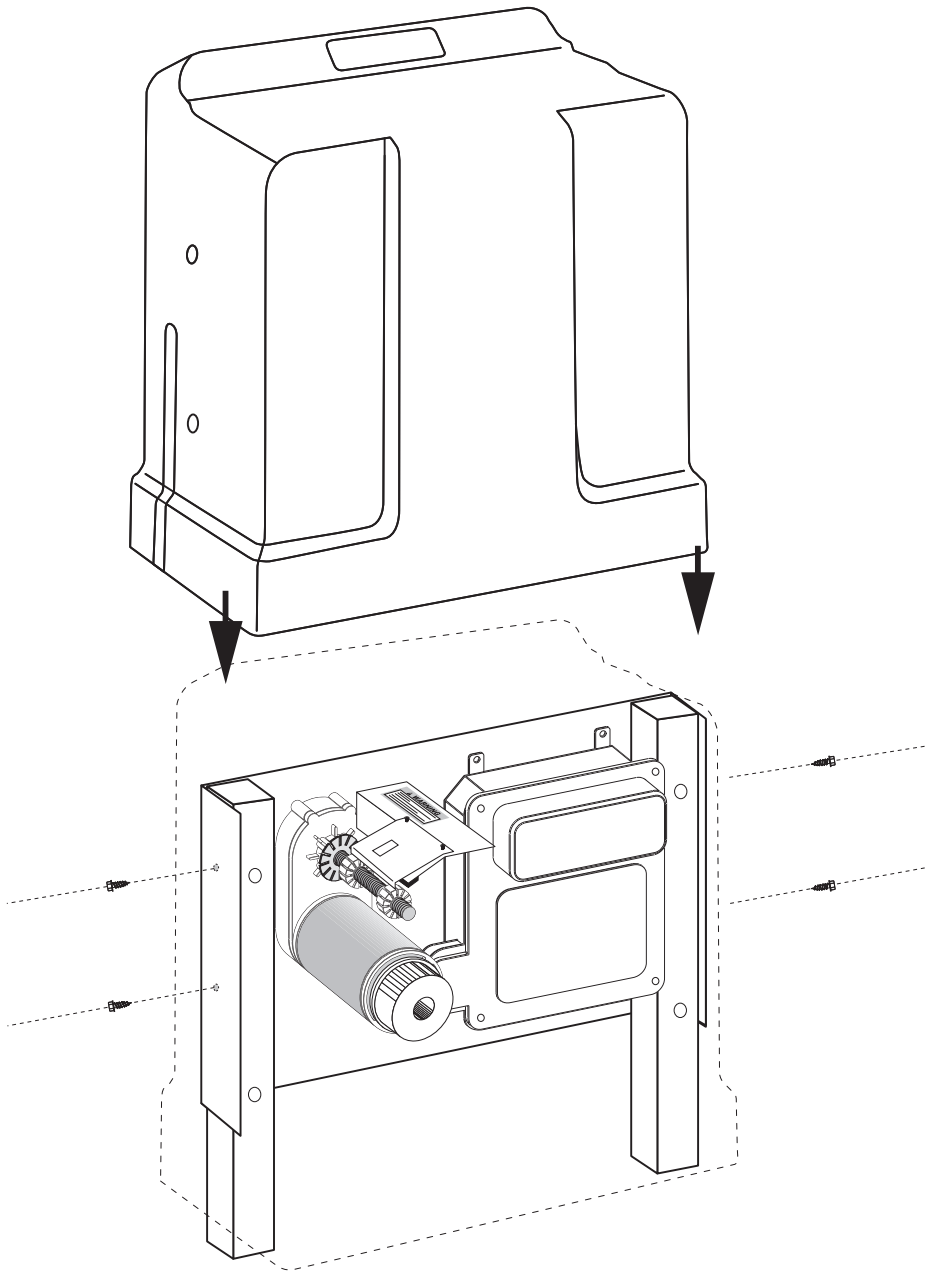

DUAL GATE SYSTEM INSTALLATION

Install the second gate operator in the same manner as the Single gate operator starting on page 4 of this manual. The second gate preparation and wiring of the second (auxiliary) operator follow on the next two pages. Once the second gate operator is installed, Set the DIP switches for DUAL gates and the order in which the gates open ("sequencing"). **Setting the Control Board for Dual Gate Installations begins on page 22.**

Second Gate (Auxiliary) Operator Parts & Hardware

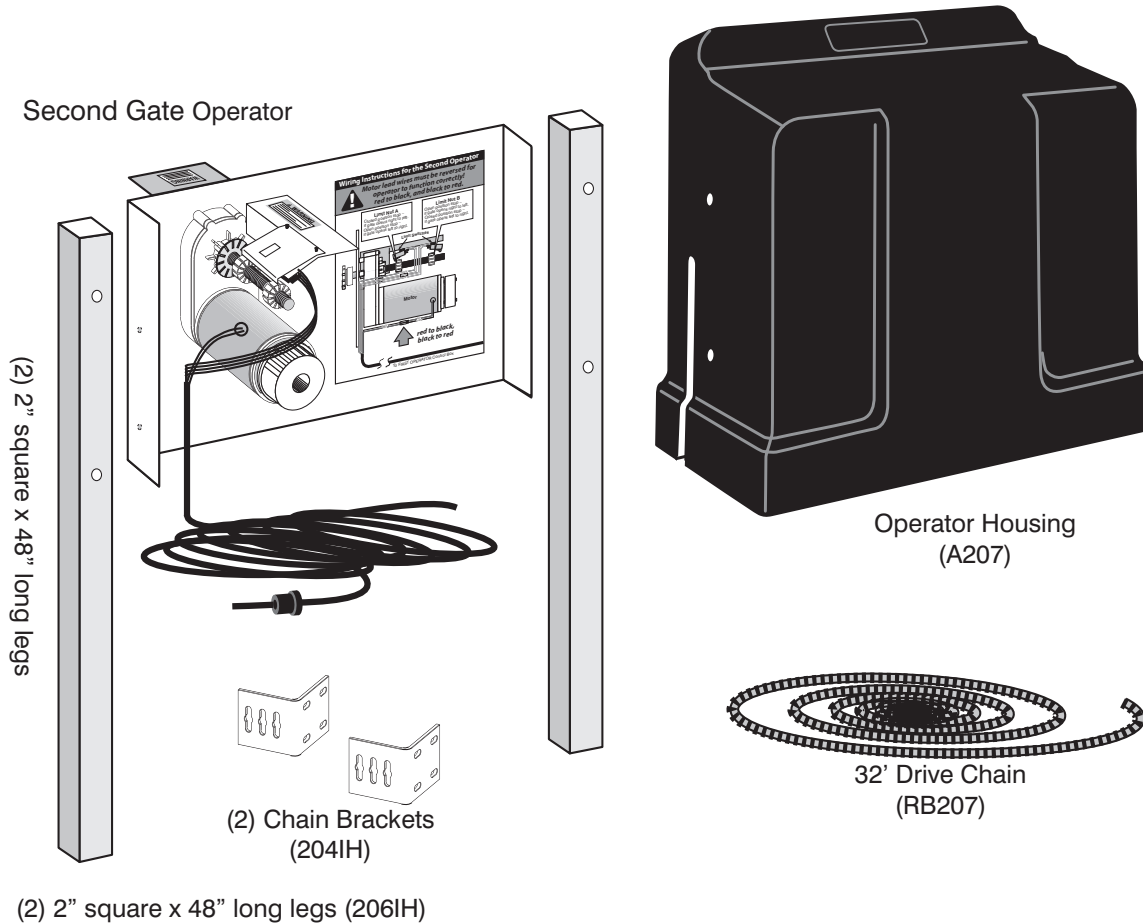

Hardware Bag

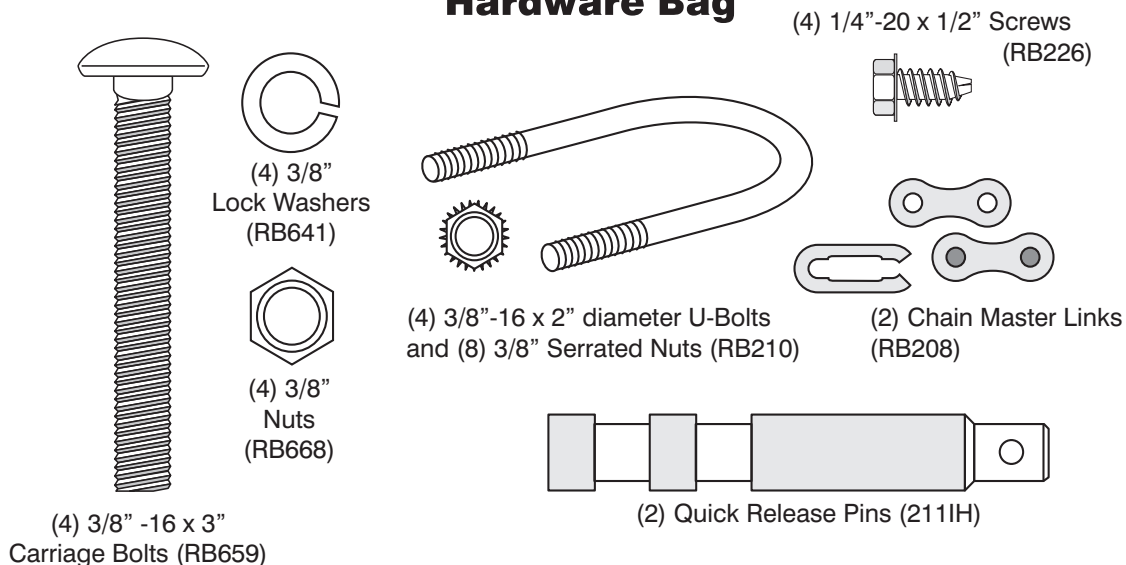

PREPARING THE GATES

Install PVC conduit (not included) needed for power cables and low voltage wiring – see illustration below. The power cable and safety edge (required) wiring should be run through PVC conduit underneath the driveway.

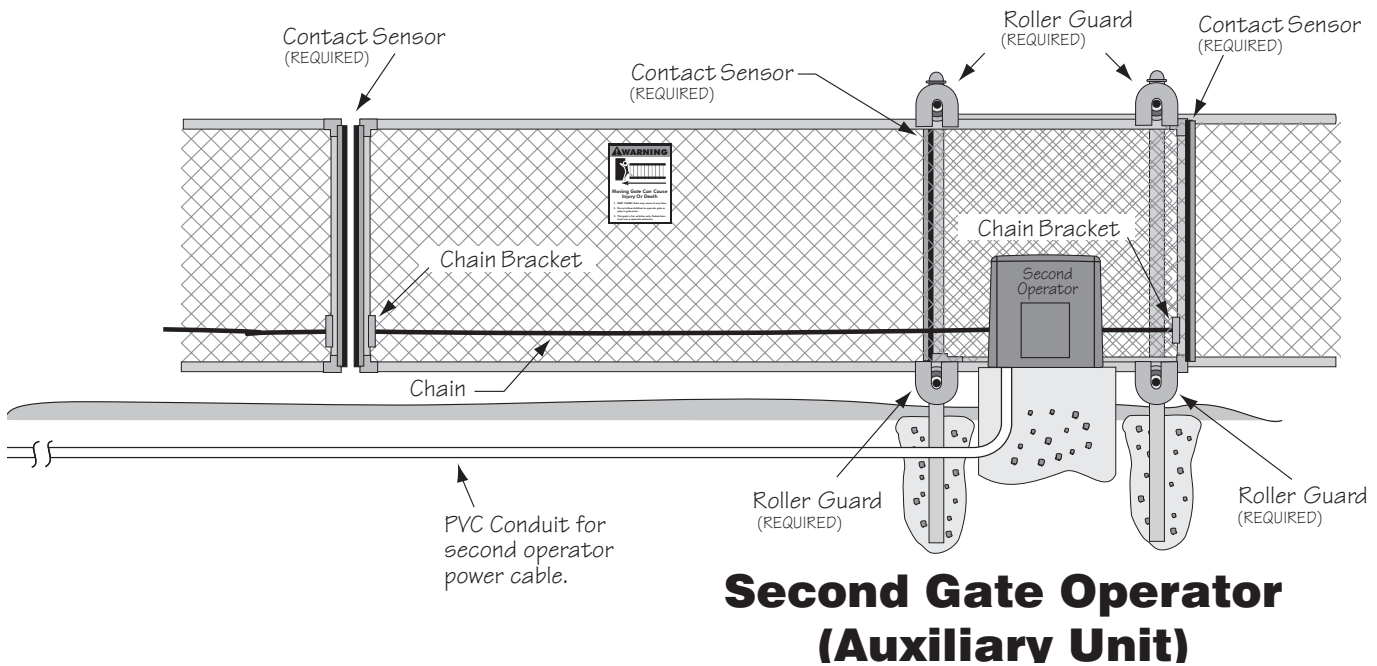
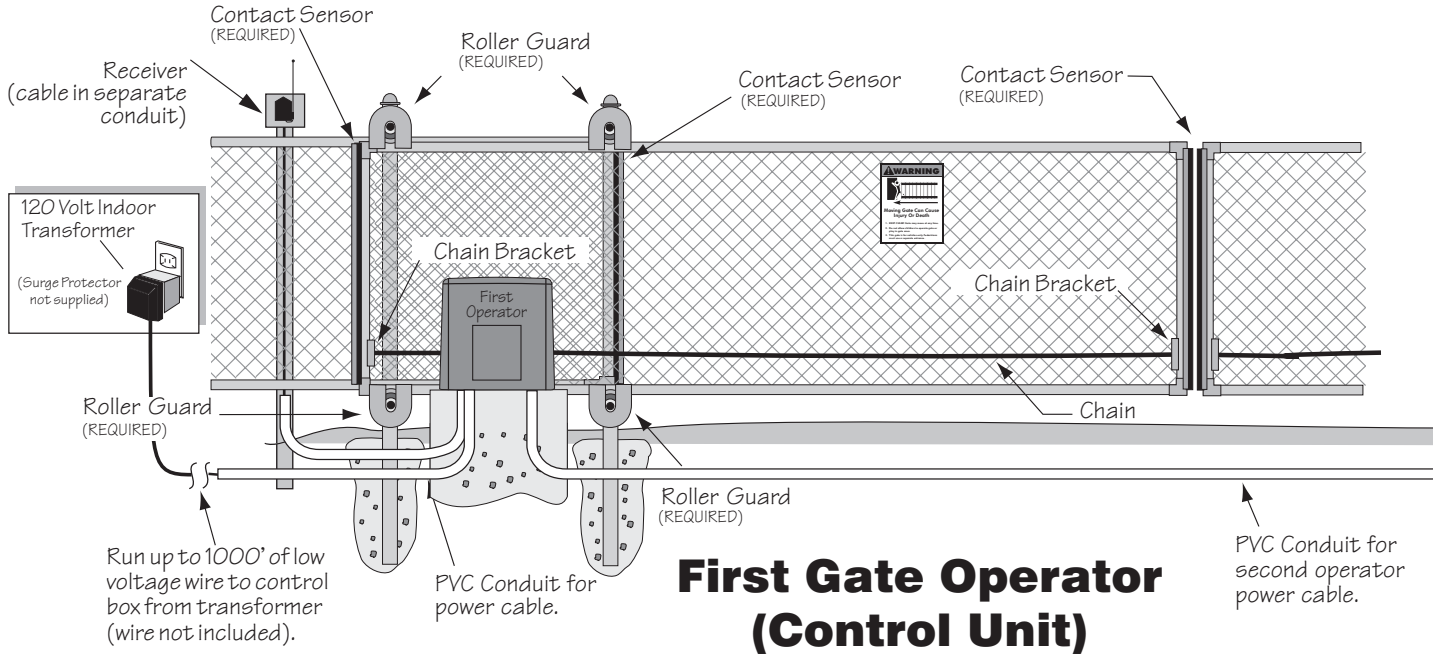

WIRING THE SECOND OPERATOR

When the units are set in place and you have completed wiring the first unit follow the instructions below to connect the 2nd operator to the system.

Step 1

Run the second power cable through PVC conduit to the Master Operator.

Step 2

With the control box open, remove a round knockout hole for Second Operator power cable. Install the strain relief for the Second Operator power cable. Pull about 6" of the power cable into the control box and tighten the strain relief nut to secure the wires.

Step 3

Connect the power cable wires to the Master operator control board as shown in the illustration.

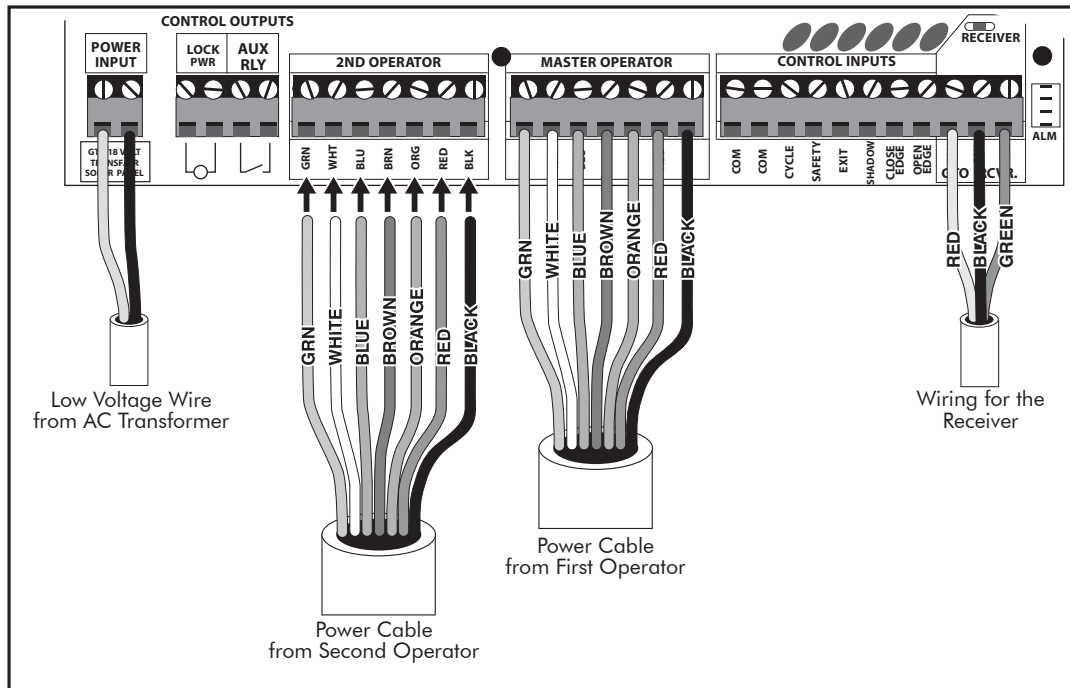
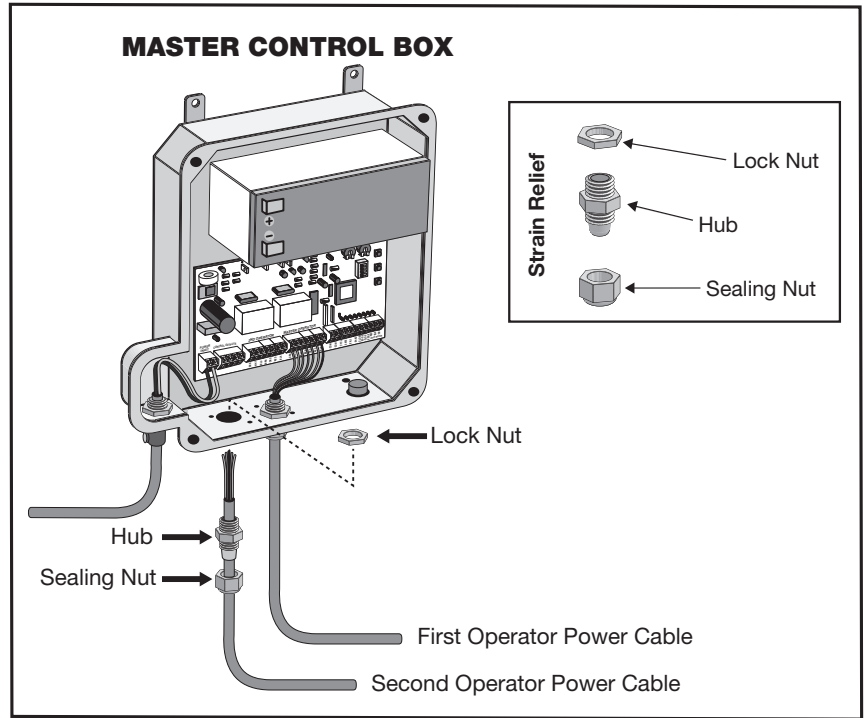

ATTACHING SECOND OPERATOR HOUSING

Install the operator housing after all installation procedures are complete. Slide operator housing over legs, align holes, and use screws provided to attach housing to operator.

IMPORTANT: Hang the two (2) GTO Warning Signs (provided) on both sides of the gate before operating. **Make sure** all warning signs and labels are in place.

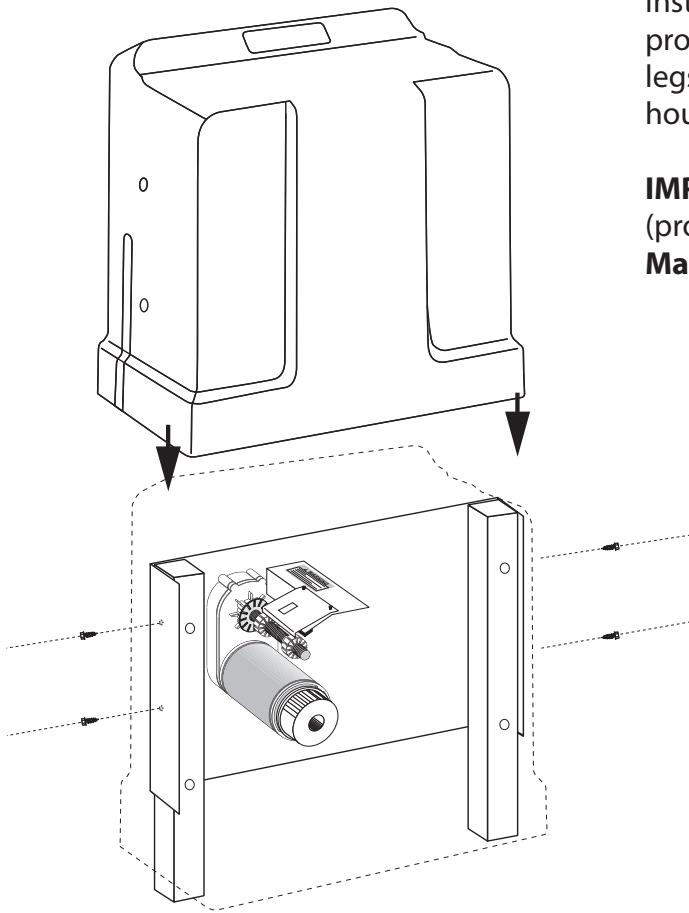

MAINTENANCE



WARNING: ALWAYS TURN OPERATOR OFF AND DISCONNECT AC POWER BEFORE ADJUSTING OR SERVICING IT!



Maintenance Schedule:

- Test the operator, accessories, and safety devices monthly.
- Service the gate operator, accessories, and safety devices regularly.

Maintenance Checklist

- Test the safety edges to make sure the gate responds.
- Check the obstruction settings (both open and close modes) see page 11.
- Lubricate and adjust the chain when necessary.
- Check for wear on all moving parts, and tighten bolts as necessary.
- Check rollers on the gate and lubricate if needed.
- Check for loose or corroded wires.
- Make sure the warning signs, roller guards, fence screen, etc. (see page ix) are installed.

VOLTAGE READINGS

18 Vac Transformer	18.0 to 22.0 Vac
10 W Solar panel (single)	18.0 to 22.0 Vdc
<i>In FULL SUN — measure voltage with the Solar Panel Disconnected.</i>	
12 V, 7 amp hour Battery	12.5 to 13.5 Vdc
<i>Measure voltage at battery terminals with battery disconnected</i>	
Charging circuit	12.0 to 14.8 Vdc
<i>Measure voltage at battery terminals with battery connected</i>	

TROUBLESHOOTING



If your gate opener does not function properly, use this guide or use the online troubleshooter at <http://support.gtoinc.com> before calling the GTO Service Department.

SYMPTOMS	CAUSES	CORRECTIVE ACTION
Unit clicks but does not operate	<ul style="list-style-type: none"> • Gate binding or not sliding freely • Motor pulling too many amps • Motor open circuit 	<ul style="list-style-type: none"> • Check replace fuse(s) • Check battery connections at battery and control board • Check motor lead connection at the control board • If this is single gate operator, make sure that DIP 3 is set for single. Turn unit off them back on. • Check battery for dead cell (load test)
Unit not responding (Amber status LED flashing) Unit works (Green Power IN LED off)	<ul style="list-style-type: none"> • Low battery (less than 12 vdc) • Unit not charging (see voltage chart) • Adverse solar conditions 	<ul style="list-style-type: none"> • Test transformer output • Test solar panels • Check battery for dead cell (load test)
Unit not responding (Amber status LED on)	<ul style="list-style-type: none"> • Transmitter not programmed correctly • Faulty accessory device 	<ul style="list-style-type: none"> • Reprogram your transmitter • Remove accessories. If unit functions - you likely have a accessory issue • Momentarily connect the CYCLE and COM on accessory terminal block. If unit functions, then you may have a faulty receiver, receiver circuit or remote transmitter
Unit not responding (Charging LED off)	<ul style="list-style-type: none"> • Unit may not be charging 	<ul style="list-style-type: none"> • Cycle power switch • Check battery voltage • Check receiver wiring • Check transformer and wiring • Check solar panel and/or solar conditions • Check battery (load test)
Unit stopping and reversing direction during operation	<ul style="list-style-type: none"> • Improper obstruction setting 	<ul style="list-style-type: none"> • Adjust gate. The gate is binding or not sliding freely • Adjust the STALL FORCE POT as needed. (see installation manual for instruction) • Check and/or remove accessory and test for proper operation

WARRANTY AND REPAIR SERVICE

If your Gate Operator is not operating properly, please follow the steps below:

1. First use the procedures found in the Troubleshooting Guide (see page 24).
2. Use the 24/7 Troubleshooting Wizard at <http://support.gtoaccess.com>.
3. If you are unable to solve the problem, call the GTO Service Department at (800) 543-1236, or (850) 575-4144. Refer to the serial number (located on the right side of the control box) and date of purchase when calling for assistance.
4. If repair or replacement of your gate operator is necessary, the Service Department will assign a Return Goods Authorization (RGA) number to you.
5. Once you have received your RGA# you are required to send in your original equipment for repair. Please refer to Manufacturers' Limited Warranty for complete details. Securely pack the component(s) authorized for return to the factory. Include a copy of your sales receipt for the purchase of the product(s). Write the RGA number issued to you on the outside of the package in **LARGE BOLD PRINT**.

Ship the package(s) freight prepaid to: GTO, 3121 Hartsfield Road, Tallahassee, Florida, USA 32303.

NOTE: Products returned to GTO without a Return Goods Authorization (RGA) number in LARGE BOLD PRINT on the outside of the package WILL NOT be accepted. Also, items returned to GTO freight collect WILL NOT be accepted.

Mighty Mule Technical Service

8:00am–7:00pm • Monday–Friday (EST)

3121 Hartsfield Road • Tallahassee, Florida, USA 32303

(800) 543-4283 • Fax (850) 575-8912

Web site www.mightymule.com

24/7 Troubleshooting Wizard: <http://support.gtoaccess.com>

ACCESSORY CATALOG

Please visit www.gtopro.com for photos and detailed descriptions of GTO Accessories. Or call 1-800-543-GATE (4283).

POWERING ACCESSORIES



Low Voltage Wire [RB509]

The 16 gauge, stranded, dual conductor low voltage Wire is for connecting the AC powered transformer, solar panel or wired accessories to the system's control board. This specially designed wire is UV treated, PVC coated, and ready for direct burial.

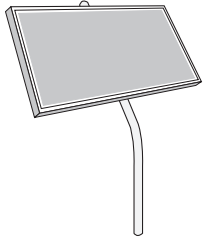

Solar Panel Kits [FM123]

If your gate operator is more than 1000 ft. away from an AC power outlet, you can choose to maintain the battery charge with the GTO Solar Panel Kit.

- 10 Watt Solar Panel Charging Kit [FM123]



Replacement Battery [RB500]

For replacement.

ENTRY AND EXIT ACCESSORIES

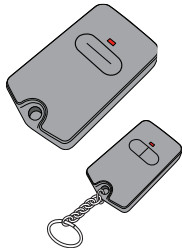

Transmitters [RB741/RB742/RB743]

Purchase an additional transmitter for each vehicle in your family. The Two-Button Transmitter can be programmed to operate both your gate operator and a garage door opener using the Universal Receiver. Or it can be programmed to open two gate operator systems.

- Single Button Transmitter [RB741]
- Dual Button Transmitter [RB742]
- Three Button Transmitter [RB743]

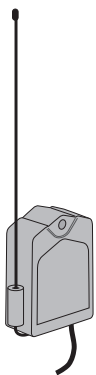

Universal Receiver [RB709U-NB]

The Universal Antenna Receiver gives you the ability to use one remote to activate your gate operator and your garage door opener. Connects to any brand garage door opener. Up to 100 ft. range.



Digital Keypad [F310]

Allow friends access to your property using an identification code that you provide. Program up to 25 entry codes for added security. Powered by three "AA" batteries (not included).

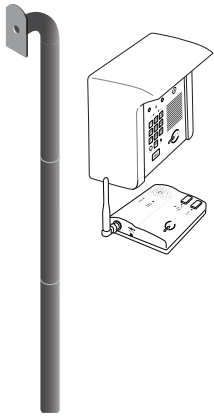

Residential Wireless Entry Intercom Keypad [F3100MBC]

Designed for added security to your automated gate with the ability to “speak to” and “screen” visitors safely from inside your home. Ideal for securing gate entrances while providing controlled access.

Gooseneck Pedestal [F100 (Inground) / F110 (Bolt-down)]

Designed to mount digital keypads, wireless intercom systems, and other access control devices for your gate automation system.

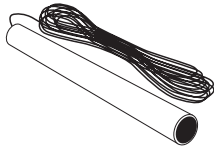

Driveway Vehicle Sensor [FM139]

Automatically activates gate operator “Hands-Free” when a vehicle exits the property. Electromagnetic sensor detects vehicles in motion.

- 50 ft. [FM139]
- 100 ft. [FM140]
- 150 ft. [FM141]
- 250 ft. [FM141-250]

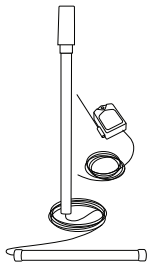

Wireless Vehicle Sensor [R4500]

Automatically activates gate operator “Hands-Free” when a vehicle exits the property. 100 ft. range between transmitter and receiver. Easy installation.

LOCKING & SECURITY ACCESSORIES

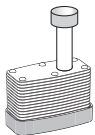

Pin Lock [FM345]

The pin lock can be inserted in the chain bracket to prevent unauthorized removal of quick release pins.

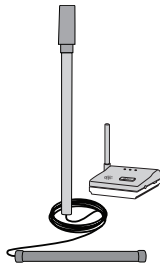

Wireless Driveway Alarm [R4450].

This device alerts you of vehicles entering your driveway (with or without an automated gate). The indoor base station signals you with a door chime when a vehicle passes the driveway sensor.

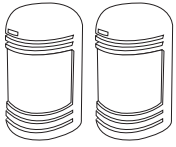

ADDITIONAL ACCESSORIES

Photo Beams [R4222]

Primary “through beam” photo beam device. Provides “non-contact” entrapment protection.



Push Button Control [RB101]

Wire this unlit push button directly to your gate operator for simple open/close/stop operation from up to 1000 ft. away. Use 16 gauge low-voltage wire.

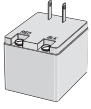

Replacement Transformer [RB570]

Standard 18 volt, 2200 mA AC transformer included with the operator to maintain battery charge.



#41 Slide Gate Chain (RB207)

The #41 chain (32' only) is used with the SL2000BE DC Slide Gate Operators.

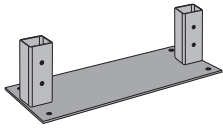

Mounting Bracket for Concrete Pad (SGMP)

This bracket mounts DC Slide operators SL2000BE to a concrete pad.



ACCESS SYSTEMS, LLC

3121 Hartsfield Road • Tallahassee, Florida, USA 32303

(800) 543-4283 • Fax (850) 575-8912

Web site www.gtoaccess.com



24/7 Troubleshooting Wizard: <http://support.gtoaccess.com>