

Nice Pro-RDFI

The compact Direct Drive solution for sprung and unsprung sectional and rolling doors, and grilles with high duty cycle requirements



Features



User friendly:

Touch screen control panel for easy set-up and installation



High speed:

Door speeds up to 36" per second



Precise:

Encoder limits guarantees positioning without mechanical limit switches, and programming of limits from floor level



Safe:

UL325 compliant with monitored photo eyes and integrated door safety catch device



Pro-RDFI

Direct Drive Motor

Robust:

Guaranteed for 300,000 cycles or two years

Easy to install:

Compact Direct Drive design makes installation directly onto the shaft of a door or grille simple and fast, eliminating the need for traditional chain and sprockets

UL325 compliant:

Fully compliant with UL325 with included photocells or optional light curtain

Safe:

Integrated door safety catch device and door cable monitor

Intelligent:

Variable frequency drive provides SmoothMove technology with Soft Start and Soft Stop door operation

Advanced:

Touch screen control panel with graphical user interface for easy set up and troubleshooting - no complicated error codes



TECHNICAL INFO

ELECTRICAL DATA

POWER SUPPLY (VAC 60 HZ)	110 - 600V
--------------------------	------------

POWER (HP)	1 - 3
------------	-------

PERFORMANCE DATA

SPEED (RPM)	24 - 58
-------------	---------

TORQUE	Up to 7000 in - lbs.
--------	----------------------

DIMENSIONAL AND GENERAL DATA

ENCLOSURE RATING	NEMA-4
------------------	--------

BORE DIAMETER	1.5"
---------------	------

Motor Dimensions (in.)

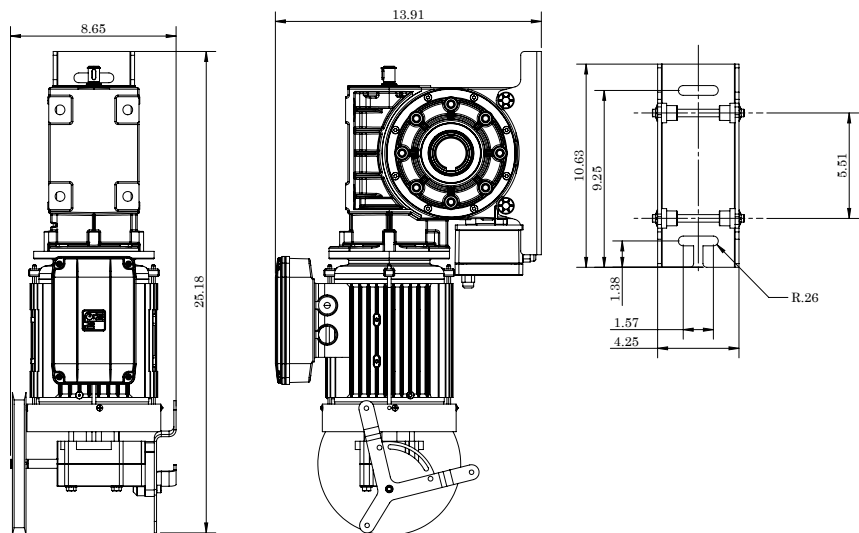

ACCESSORIES INCLUDED



NEMA-4 photo eyes

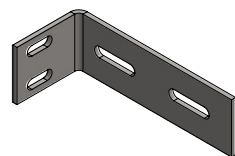

Mounting brackets (2)

Panel Dimensions (in.)

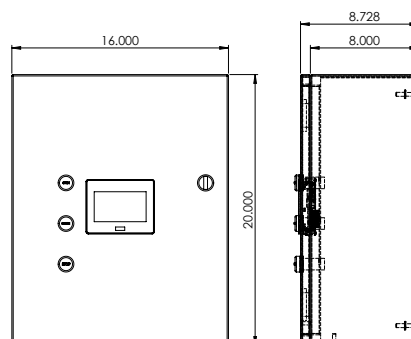

877-888-1116 • niceforyou.com

Nice is a premier manufacturer of industrial, commercial, and residential door openers.

033122 N0016