

# SG - SG-D

## Barrier Gate Operator

### Installation Guide

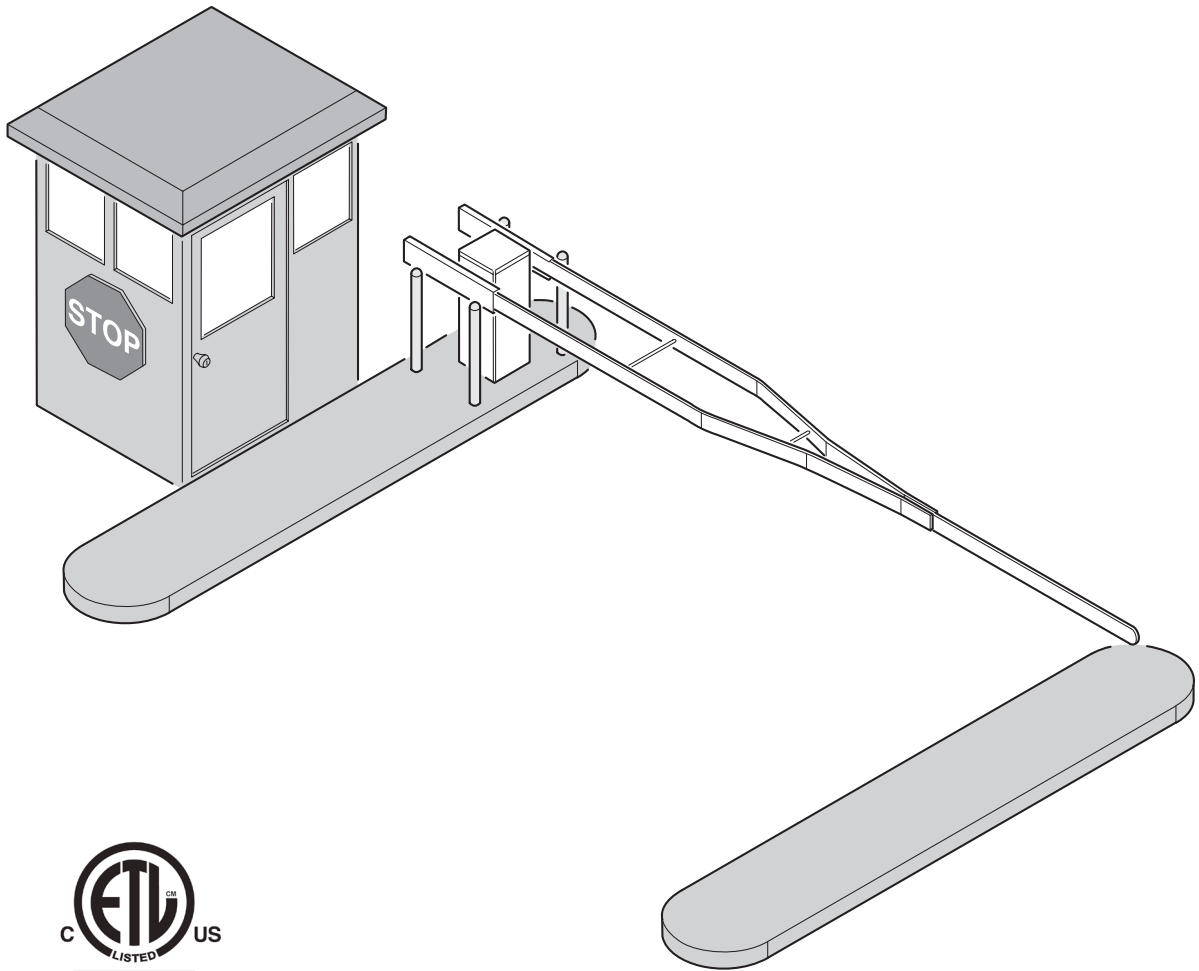

**Intertek**

Operator models contained in this manual  
conform to UL325 standard for use in  
Class I, II, III, and IV applications

# **Linear**<sup>®</sup>

USA & Canada (800) 421-1587 & (800) 392-0123  
(760) 438-7000 - Toll Free FAX (800) 468-1340  
[www.linearcorp.com](http://www.linearcorp.com)

# Table of Contents

- Pre-installation Information . . . . .1
  - Before You Begin.....1
  - Gate Operator Classifications . . . . .1
  - Approved Obstruction Detection Devices . . . . .1
- Safety Information and Warnings . . . . .1
  - Regulatory Warnings . . . . .1
- Wiring Specifications . . . . .2
  - AC Power Wiring . . . . .2
  - DC Control and Accessory Wiring. . . . .2
- Installation on Concrete Curb . . . . .3
- Barrier Gate Arm Installation . . . . .4
  - Attaching the Gate Arm . . . . .4
  - Installing the Counterweights . . . . .4
- Operator Preparation . . . . .5
  - Gear Reducer Vent Plug. . . . .5
  - Limit Cam Adjustments . . . . .5
- Operator Setup . . . . .6
  - Controller Access. . . . .6
  - AC Power Connection . . . . .6
  - Earth Ground . . . . .6
- Controller Features . . . . .7
- Indicator Descriptions . . . . .8
- Terminal Descriptions. . . . .9
- Operator Accessory Connections . . . . .10
- Basic Controller Programming . . . . .11
  - Programming Overview . . . . .11
  - Entering Programming Mode. . . . .11
  - Exiting Programming Mode . . . . .11
  - Programming Keystrokes . . . . .11
  - Left or Right Hand Operation. . . . .11
  - Dual Gate Enable . . . . .11
  - Auto Close Timer . . . . .11
  - Run Alarm and Pre-start Alarm . . . . .11
  - Maximum Close Direction Current Setting . . . . .12
- Advanced Controller Programming . . . . .12
  - Entering Advanced Programming Mode. . . . .12
  - Maximum Run Time . . . . .12
  - Single Button Input Setup . . . . .13
  - Stagger Mode. . . . .13
  - Stagger Delay Time . . . . .13
  - Auxiliary Relay Mode . . . . .13
  - Reverse Delay Time . . . . .13
  - Low Power Mode . . . . .14
  - Power Failure Mode . . . . .14
  - Soft Start/Stop Duration . . . . .14
  - Reset Cycle Count . . . . .14
  - Maintenance Alert Trigger . . . . .15
  - Open/Reset Input. . . . .15
  - Anti-tailgate . . . . .15
  - Radio Enable . . . . .15
  - Antenna Installation . . . . .15
  - Radio Transmitter Learn. . . . .16
  - Radio Transmitter Delete . . . . .16
  - MGT Obstacle Transmitter Learn . . . . .16
  - MGT Obstacle Transmitter Delete . . . . .16
  - Motor Type Selection . . . . .16
  - Reset Controller to Factory Defaults. . . . .16
- Free Gate Loop Layout Illustration . . . . .17
- Pay Gate Loop Layout Illustration . . . . .18
- Dual Gate Installations. . . . .19
- Gate Operation . . . . .19
  - Open Button . . . . .19
  - Close Button. . . . .19
  - Stop Button . . . . .19
  - Single Input. . . . .19
  - Fire Department Input . . . . .19
  - Open Input . . . . .19
  - Open/Reset Input. . . . .19
  - Close Obstruction Input. . . . .19
  - Reverse Input . . . . .19
  - Open Loop . . . . .19
  - Reverse Loop . . . . .19
  - Reset Loop . . . . .19

- Operation Indications . . . . .20
  - Power-up Display . . . . .20
  - Idle Condition . . . . .20
  - Last Gate Position/Condition . . . . .20
  - Reverse Delay. . . . .20
  - Run Timer . . . . .20
- Error Indications . . . . .20
  - Entrapment . . . . .20
  - COMM LINK Connection Failure . . . . .20
  - MGT Obstacle Transmitter Trouble . . . . .20
  - Maximum Run Time Exceeded . . . . .20
- Troubleshooting . . . . .21
  - Contacting Technical Support . . . . .21
  - Operator fails to start . . . . .21
  - Motor operates, but gate does not move . . . . .21
  - Motor sounds like it is working harder than normal. . . . .21
  - Limit switch getting out of time . . . . .21
  - Gate stopping part way open or closed . . . . .21
  - Gate staying open with automatic system . . . . .21
  - How to Order Replacement Parts . . . . .21
- Model SG Exploded View . . . . .22
- Model SG-D Exploded View . . . . .23
- Model SG & SG-D Arm Parts List . . . . .24
- Model SG and SG-D Maintenance . . . . .25
  - Battery Maintenance . . . . .25
- Preventative Maintenance . . . . .25
  - General . . . . .25
  - Lubrication . . . . .25
  - 6-Month Preventative Maintenance . . . . .25
- FCC Notice . . . . .25
- Gate Operator Installation Checklist . . . . .26



## Pre-installation Information

### Before You Begin...

Before unpacking, inspect the carton for exterior damage. If you find damage, advise the delivery carrier of a potential claim. Inspect your package carefully. You can check your accessory box parts with the enclosed packing slip for your convenience. Claims for shortages will be honored for only 30 days from the date of shipment.

Before installing the operator, read this manual completely to ensure all requirements for proper installation are present. Verify that the voltage to be used matches the voltage of the operator.

If you have any questions about the requirements for proper installation of this gate operator contact technical support at 800-421-1587

### Gate Operator Classifications

All gate operators can be divided into one of four different classifications, depending on their design and usage. Install this gate operator only when the operator is appropriate for the construction and usage class as defined below:

- **Class I Residential Vehicular Gate Operator**  
A vehicular gate operator intended for use in a home or for one to four single family dwellings with a common garage or parking area associated with these dwellings.
- **Class II Commercial / General Access Vehicular Gate Operator**  
A vehicular gate operator intended for use in a commercial location or building such as a multi-family housing unit of five or more single family units, hotel, retail store or other building servicing the general public.
- **Class III Industrial / Limited Access Vehicular Gate Operator**  
A vehicular gate operator intended for use in an industrial location or building such as a factory or loading dock area or other location not intended to service the general public.
- **Class IV Restricted Access Vehicular Gate Operator**  
A vehicular gate operator intended for use in a guarded industrial location or building such as an airport security area or other restricted access locations not servicing the general public, in which unauthorized access is prevented via supervision by security personnel.

**Linear barrier gate operator models SG and SG-D meet the requirements for all four classifications.**

### Recommended Obstruction Detection Devices

The following contact or non-contact obstruction detection devices have been approved for use with this swing gate operator as part of a UL325 compliant installation:

- **Contact Edges**  
Miller Edge Models: MGO20, MGR20, MGS20
- **Wireless Contact Adapter**  
GTO Models: SGEKAC, SGEKDC, SGET, SGER
- **Obstruction Input Expansion**  
Miller Edge Model: MIM-62
- **Photoeyes**  
Omron Model: E3K-R10K4-NR  
Miller Edge Models: RG-K-R, PG-K-R50  
EMX Models: IRB-MON, IRB-RET

## Safety Information and Warnings

THE FOLLOWING FORMATS ARE USED FOR SAFETY NOTES IN THESE INSTRUCTIONS.

**⚠ CAUTION ⚠**  
This type of warning note is used to indicate the possibility of damage to the barrier arm or gate operator.

**⚠ WARNING ⚠**  
This type of warning note is used to indicate possible mechanical hazards that may cause serious injuries or death.

**⚡ WARNING ⚡**  
This type of warning note is used to indicate possible electrical shock hazards that may cause serious injuries or death.

### Regulatory Warnings

Read the following before beginning to install this swing gate operator:

## IMPORTANT INSTALLATION SAFETY INSTRUCTIONS

### ⚠ WARNING ⚠

## TO REDUCE THE RISK OF SEVERE INJURY OR DEATH TO PERSONS, REVIEW THESE INSTALLATION SAFETY STEPS BEFORE PROCEEDING

1. READ AND FOLLOW ALL INSTALLATION INSTRUCTIONS.
2. Read the blue "Safety Instructions" brochure enclosed with the packet of information. If any pages are missing or are unreadable, or you do not have the safety instructions, please call Linear at 1-800-333-1717 to request additional copies.
3. ALL ELECTRICAL CONNECTIONS TO THE POWER SUPPLY MUST BE MADE BY A LICENSED ELECTRICIAN AND MUST OBSERVE ALL NATIONAL AND LOCAL ELECTRICAL CODES.
4. A separate power-disconnect switch should be located near the operator so that primary power can be turned off when necessary.
5. Never connect a button station within reach of the barrier gate or on the side of the gate operator.
6. Do not adjust the operator controller's current sensing feature too high. It should be adjusted high enough to keep the gate from falsely triggering the sensing, but no higher than necessary for the gate to operate. DO NOT DEFEAT THE PURPOSE OF THIS FUNCTION!
7. You must install all required safety equipment.
8. UL325 Compliance requires the use of contact edges or photoelectric controls on all automatic or remotely-controlled gate operators.
9. The operator is intended for installation only on gates used for vehicles. Pedestrians must be supplied with a separate access opening. The pedestrian access opening shall be designed to promote pedestrian usage. Locate the gate such that persons will not come into contact with the vehicular gate during the entire path of travel of the vehicular gate.

## Wiring Specifications

Refer to the following steps for details on power and accessory wiring for the operator.

**⚡ WARNING ⚡**

**ALL AC ELECTRICAL CONNECTIONS TO THE POWER SOURCE AND THE OPERATOR MUST BE MADE BY A LICENSED ELECTRICIAN AND MUST OBSERVE ALL NATIONAL AND LOCAL ELECTRICAL CODES.**

### USE COPPER WIRE ONLY!

#### AC Power Wiring

1. Find the listing on this page corresponding to the model, voltage and horsepower rating of your operator.
2. The distance shown in the table is measured in feet from the operator to the power source. **DO NOT EXCEED THE MAXIMUM DISTANCE.** These calculations have been based on standard 115 V and 230 V supplies with a 10% drop allowable. If your supply is under the standard rating, the runs listed may be longer than what your application will handle, and you should not run wire too near the maximum distance for the gauge of wire you are using.
3. When large-gauge wire is used, a separate junction box (not supplied) may be needed for the operator power connection.
4. Wire length calculations are based on the National Electrical Code, Article 430 and have been carefully determined based on motor inrush, brake solenoids, and operator requirements.
5. Connect power in accordance with local codes. **The green ground wire must be properly connected.**
6. Wire insulation must be suitable to the application.
7. Electrical outlets are supplied in all 115 VAC models for convenience with occasional use or low power consumption devices only. If you choose to run dedicated equipment from these devices, it will decrease the distance for maximum length and the charts will no longer be accurate.

#### DC Control and Accessory Wiring

1. **All control devices are now 24 VDC, which can be run up to 2000 feet with 14 AWG wire.**
2. Control wiring must be run in a separate conduit from power wiring. Running them together may cause interference and faulty signals in some accessories.
3. A three-wire shielded conductor cable is required to connect two operators together for dual operation. You must use Belden 8760 Twisted Pair Shielded Cable (or equivalent) only – P/N 2500-1982, per foot). See Page 19 for details of this connection. **Note: The shield wire should be connected in both the operators.**

MODEL SG POWER WIRING			
VOLTS & HP	MAXIMUM DISTANCE (FEET)		WIRE GAUGE
	SINGLE	DUAL	
115 VOLTS 1/2-HP	222	111	12
	354	177	10
	566	283	8
	900	450	6
230 VOLTS 1/2-HP	894	447	12
	1422	711	10
	2264	1132	8
	3600	1800	6

MODEL SG-D POWER WIRING			
VOLTS & HP	MAXIMUM DISTANCE (FEET)		WIRE GAUGE
	SINGLE	DUAL	
115 VOLTS 1/2-HP	222	111	12
	354	177	10
	566	283	8
	900	450	6

## Installation on Concrete Curb

The barrier gate operator bolts to a concrete island or curb.

1. Un-crate the gate. Avoid damaging the cabinet finish.
2. Leave the machine bolted to the bottom pallet until ready to install.
3. Open the cabinet door.
4. Remove the bolts holding the gate to its pallet and place the machine in position on the curb. Refer to your Equipment Layout (EL) drawing for proper positioning of your gate.
5. With a pencil, mark the location of the mounting holes on the concrete.
6. Set the gate aside. Drill all four mounting holes using a 3/4" diameter rotary hammer percussion drill bit. Insert lag screw anchors for 1/2" lag bolts. Place the gate back in position, and anchor it with 1/2" lag bolts and flat washers. Lubricate the bolts before installation. Flat washers have been supplied to go between pavement and cabinet. Linear highly recommends using the corner mounting holes when mounting barrier gates.
7. Proceed with the rest of the installation process.

### ⚠ WARNING ⚠

The gate must be installed in a location so that enough clearance is supplied between the gate and adjacent structures when opening and closing to reduce the risk of entrapment.

### ⚠ WARNING ⚠

Do not adjust the force setting to compensate for an improperly installed, improperly functioning, or damaged gate.

**⚠ WARNING ⚠**  
 The operator is intended for installation only on gates used for vehicles. Pedestrians must be supplied with a separate access opening. The pedestrian access opening shall be designed to promote pedestrian usage. Locate the gate such that persons will not come into contact with the vehicular gate during the entire path of travel of the vehicular gate.

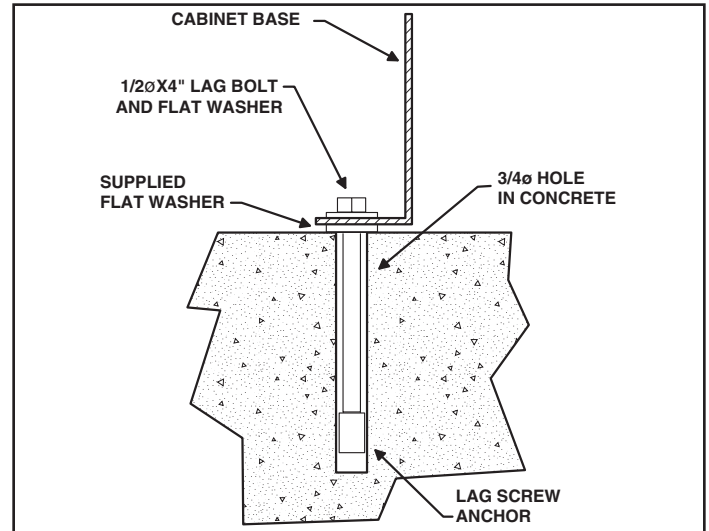

Figure 1. Concrete Lag Anchor Detail

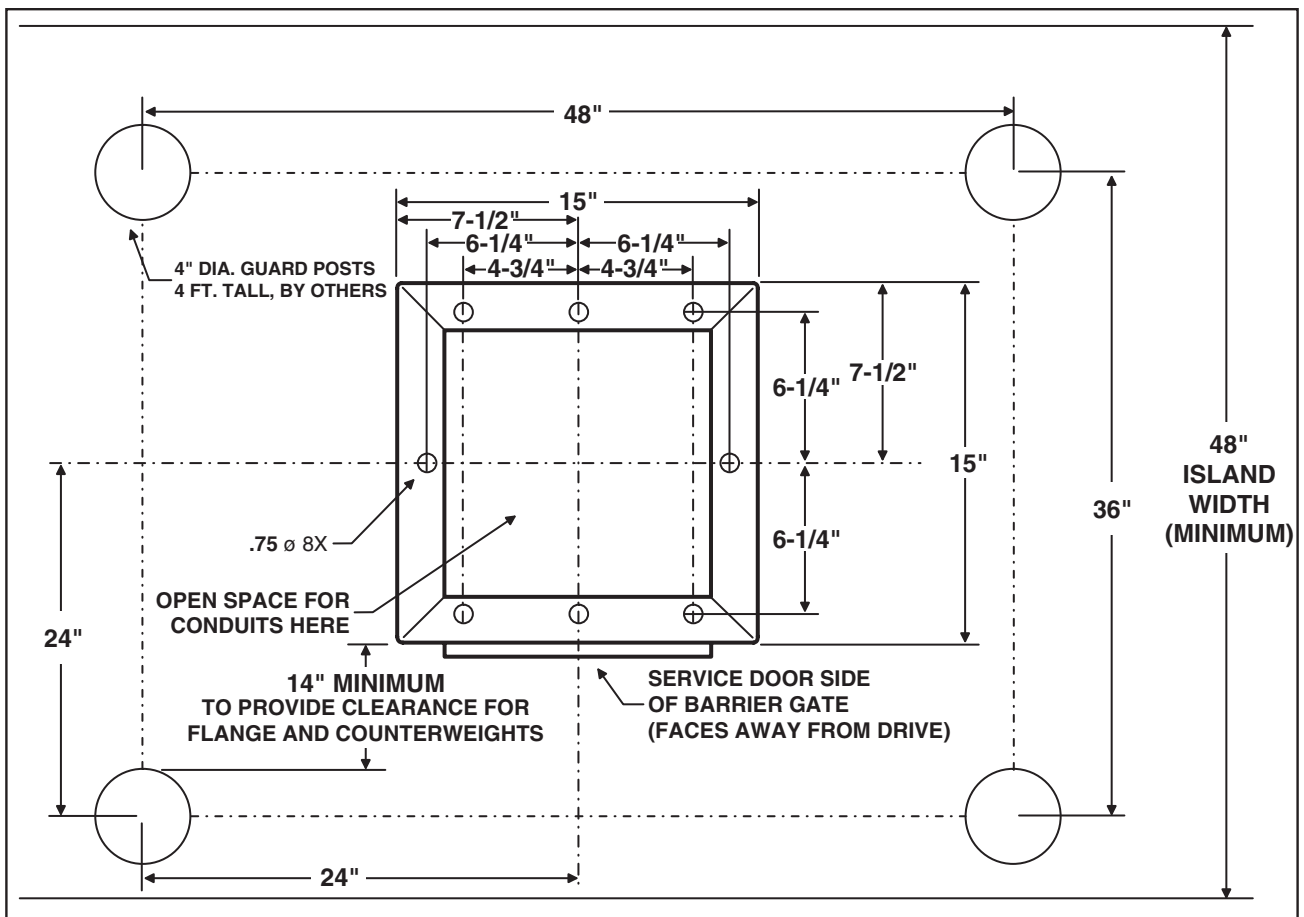

Figure 2. Barrier Gate Mounting Specifications

## Barrier Gate Arm Installation

The barrier gate arm connects to the operator with the arm attachment channel and gate arm flange. Counterweights in the attachment channel balance the gate arm for smooth operation.

✓ **NOTE:** Numbered items in these drawings are for instructional reference only. For actual part numbers, go to the parts lists in the back of this booklet.

### Attaching the Gate Arm

1. Assemble the SG arm on the ground first, making sure to leave all fasteners loose, including the spreader arms (Parts #4 & #7).
2. Make sure the barrier gate is in the full closed position.
3. With someone's assistance, lift the arm up to a height even with the barrier gate flange. The far end should either be supported by something of equal height as the flange, or be held by someone throughout the next steps.
4. Assemble the wood arms (#10) between the attachment channels (#8) and the flange and bolt together. Tighten these bolts (#9) firmly.
5. Tighten all bolts (#3) where the three pieces of wood arm come together.
6. Tighten up the nuts (#6) on the spreader arms (#4 & #7) until the plates (#5) are tight against the wood.
7. The arm should have a curved, wishbone appearance once finished.

### Installing the Counterweights

1. Align the holes in the counterweights (#11) with the holes in the barrier gate attachment channels (#8).
2. Fasten the counterweights (#11) to the barrier gate attachment channels (#2) using the hardware provided (#12).

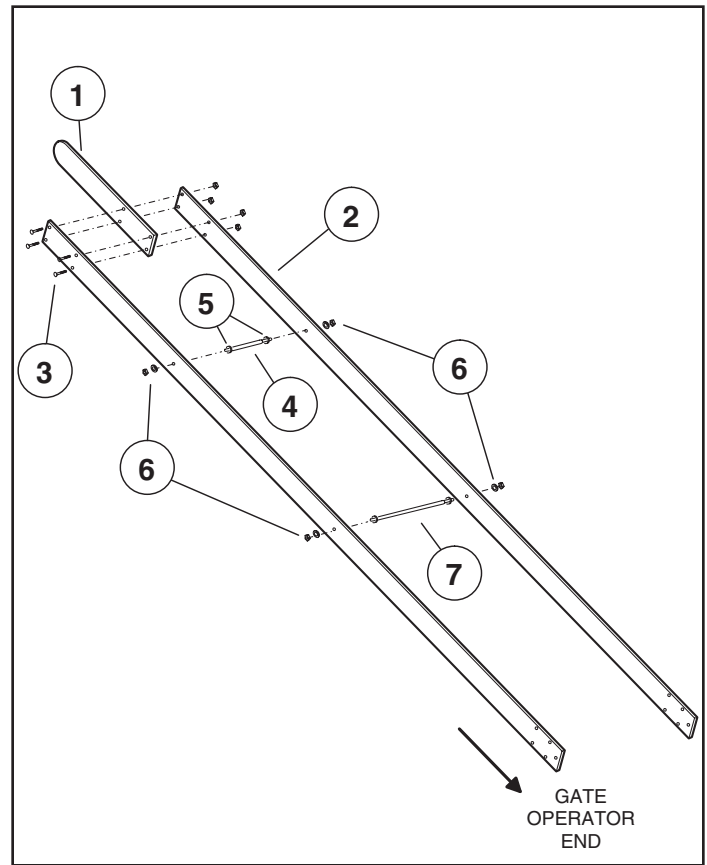

Figure 3. Wishbone Arm Assembly

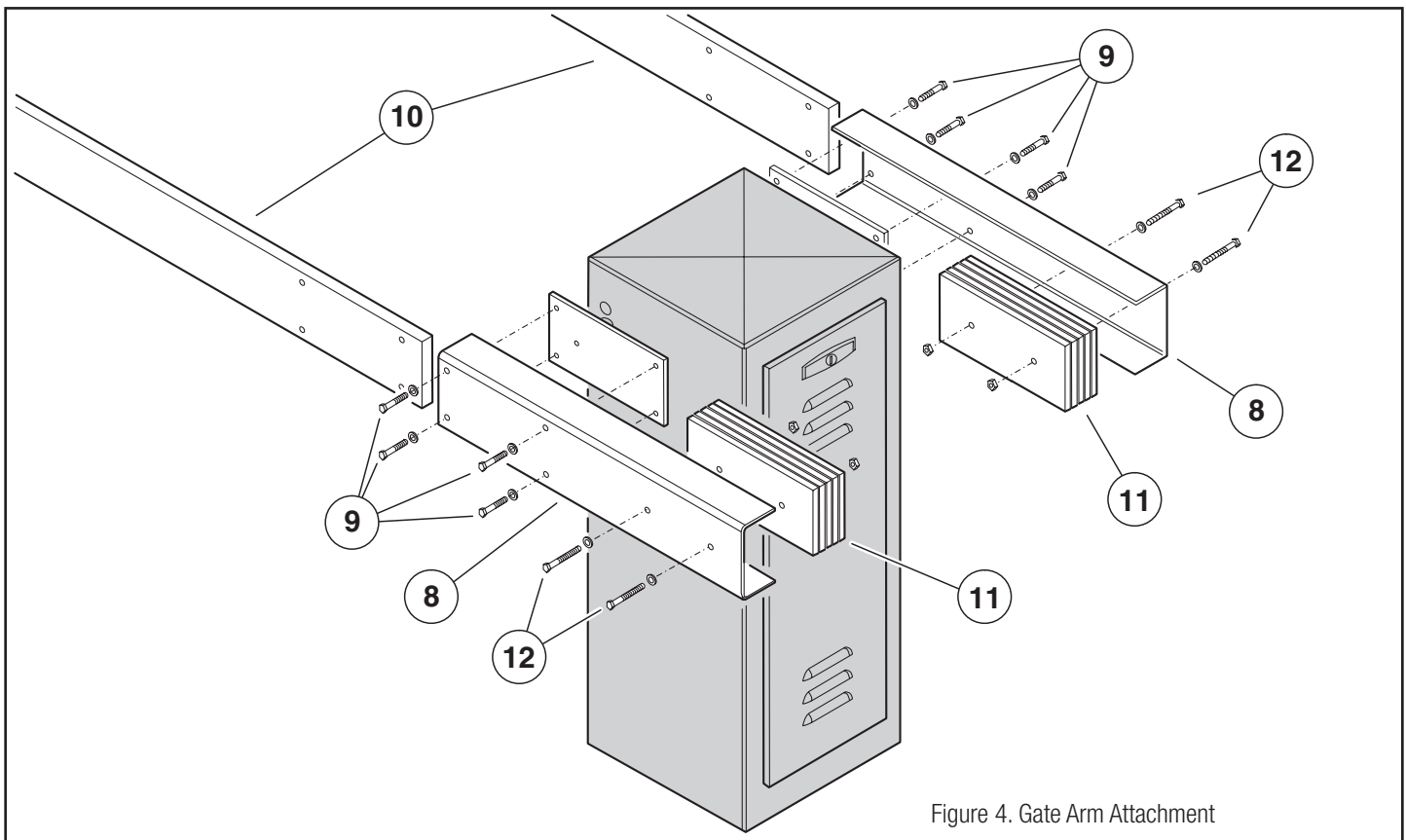

Figure 4. Gate Arm Attachment



## Operator Preparation

### Gear Reducer Vent Plug

In order to keep gear oil from spilling out during shipping, gear reducers used in the SG and SG-D barrier gate operators have a sealed vent plug installed at the factory.

Leaving the vent plug installed, remove the vent plug's breather pin to allow the gear box to vent (see Figure 5). The breather pin can be discarded.

### Limit Cam Adjustments

The limit cams for all models of barrier gate operators have been pre-set at the factory for approximately 90 degrees of motion. If you need to adjust this further, see Figure 6 and follow the directions below.

1. For **more downward travel**, loosen the wingnut on the LSC-1 (down) limit cam and rotate the cam slightly in the "B" direction.
  2. For **less downward travel**, loosen the wingnut on the LSC-1 (down) limit cam and rotate the cam slightly in the "A" direction.
  3. For **more upward travel**, loosen the wingnut on the LSO-1 (up) limit cam and rotate the cam slightly in the "A" direction.
  4. For **less upward travel**, loosen the wingnut on the LSO-1 (up) limit cam and rotate the cam slightly in the "B" direction.
- ✓ **NOTE:** If the barrier gate operator has been custom configured by the factory for reverse arm operation (where the closed barrier arm sticks out from the service door side of the operator) the limit switches shown in Figure 6 will be reversed. The top limit switch will be the open limit, the bottom limit switch will be the close limit.

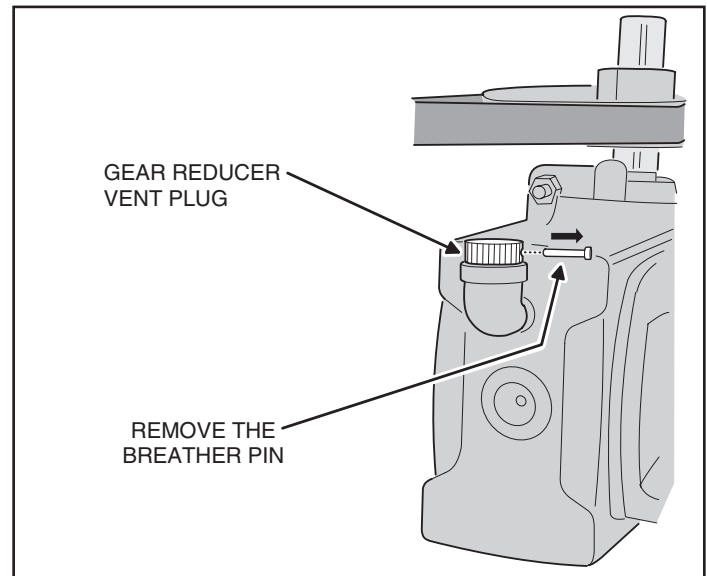

Figure 5. Vent Plug Installation

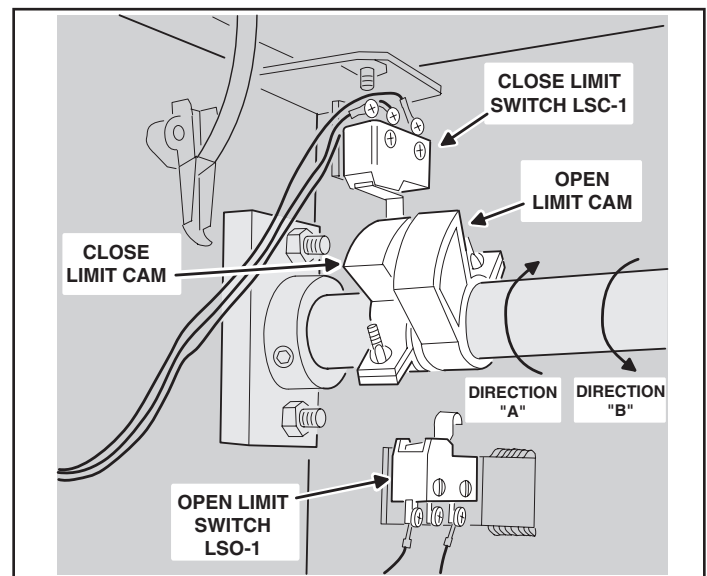

Figure 6. Limit Cam Adjustment

## Operator Setup

### Controller Access

The Controller in models SG and SG-D is located under the operator's top cover.

To access the Controller, from inside the operator, flip the two cover release latches up to unlock the operator's top cover. Remove the cover to expose the Controller.

The Controller is protected by a plastic dust cover. To remove the dust cover, loosen the cover's wing-screw and lift the cover off.

### AC Power Connection

All Linear gate operators are supplied with a power disconnect switch to turn on and off the power available to the operator (see Figure 8). Following wiring specifications on Page 2, incoming power should be brought into the operator and connected to the labeled pigtail leads from the disconnect box.

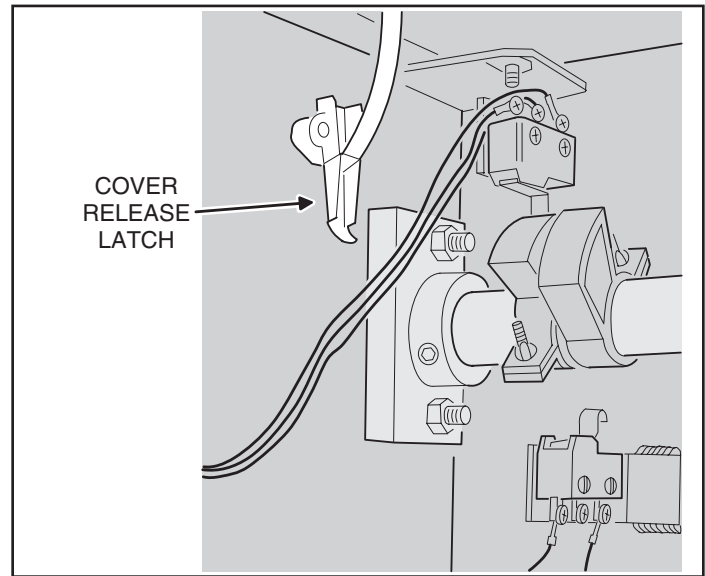

Figure 7. Cover Release Latch

**⚡ WARNING ⚡**

**ALL AC ELECTRICAL CONNECTIONS TO THE POWER SOURCE AND THE OPERATOR MUST BE MADE BY A LICENSED ELECTRICIAN AND MUST OBSERVE ALL NATIONAL AND LOCAL ELECTRICAL CODES. POWER SUPPLY MUST BE OF CORRECT VOLTAGE AND PHASE.**

- ✓ **NOTE:** FOR SOLAR POWERED UNITS ONLY: The APeX Controller's AC power disconnect switch does not turn off the Apex DC power when connected to solar panels. It will however, disconnect DC motor power. Unplug the solar panel input on the front of the Apex Controller prior to servicing the unit.

Proper thermal protection is supplied with the operator. The motor contains a thermal overload protector to guard from overheating the motor due to overload or high-frequency operation. To reset the motor after an overload, press the red button on the end of the motor after the motor has cooled down.

### Earth Ground

Install a ground rod and connect it to the operator's frame in every gate operator installation. A good earth ground is necessary to allow the Controller's built-in surge and lightning protection circuitry to work effectively. **The physical bolting of the operator to the mounting pad is not sufficient for a good earth ground.**

- ✓ **NOTE:** Do not splice the ground wire. Use a single piece of solid copper 12 AWG wire between the ground rod and the operator.

1. Install an 8-foot long copper ground rod next to the operator mounting pad within three feet of the operator.
2. Use a clamp to connect a solid copper 12 AWG ground wire to the ground rod.
3. Route the ground wire to the operator.
4. Connect the ground wire to the operator's frame.

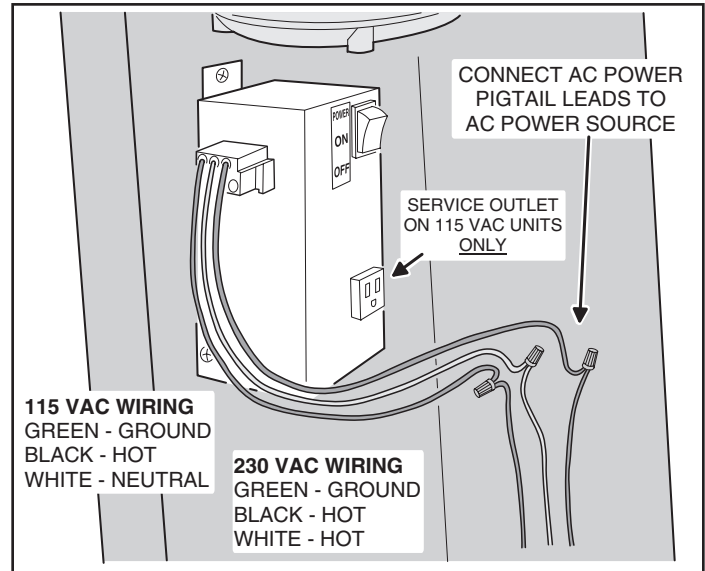

Figure 8. Power Disconnect Box Wiring

**⚠ WARNING ⚠**

**Always disconnect power from operator before servicing. Always keep clear of gate arm during operation.**



# Controller Features

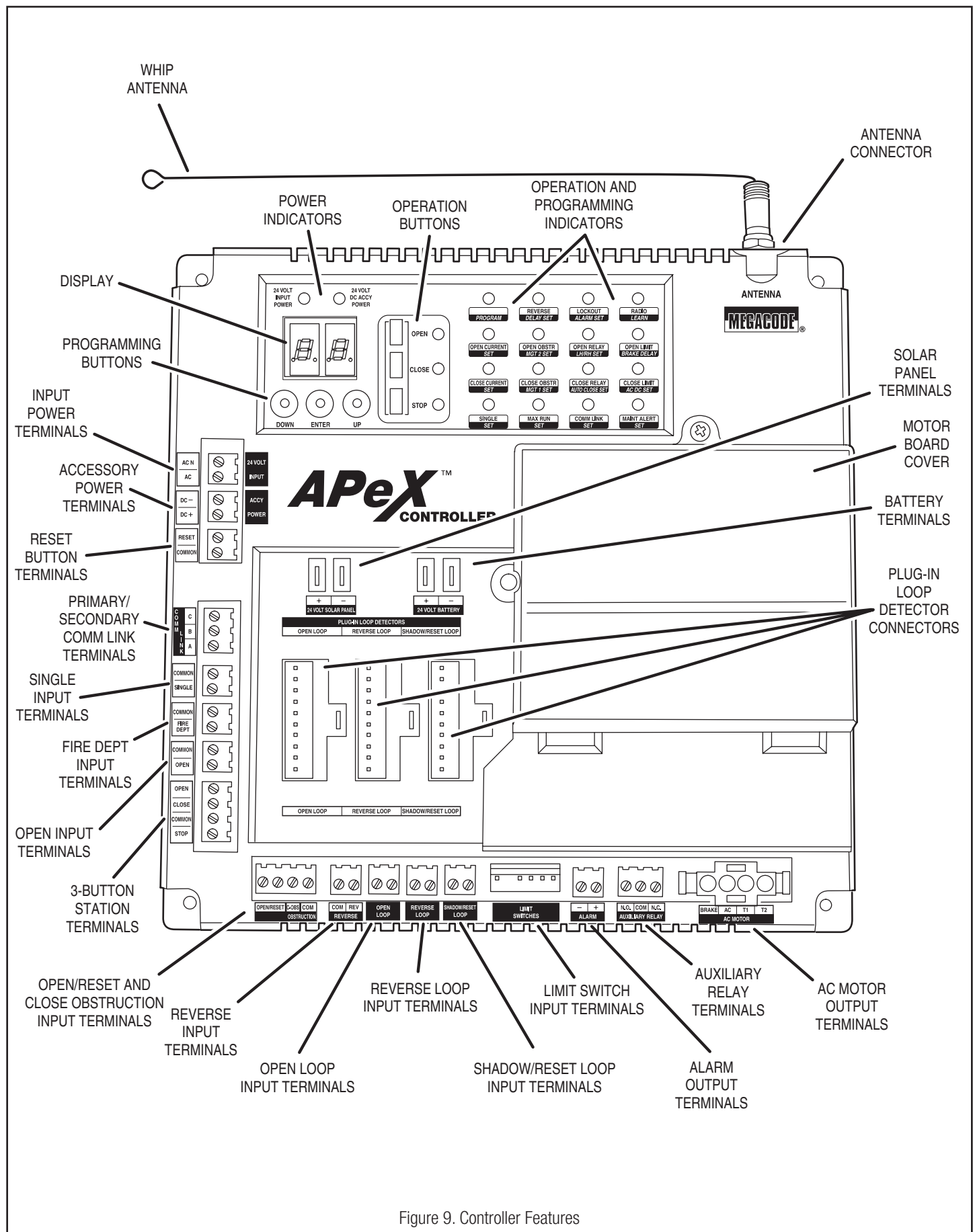

Figure 9. Controller Features

# Indicator Descriptions

INDICATOR DEFINITION		INDICATION WHEN LIT DURING NORMAL OPERATION	INDICATION WHEN LIT DURING PROGRAMMING
OPERATION	PROGRAMMING		
24 VOLT INPUT POWER		LOW VOLTAGE AC POWER IS PRESENT	
24 VOLT DC ACCY POWER		LOW VOLTAGE DC POWER IS PRESENT	
OPEN		OPEN SIGNAL PRESENT FROM THE INTERNAL RECEIVER OR AN EXTERNAL DEVICE CONNECTED TO THE OPEN INPUT TERMINAL	
CLOSE		CLOSE SIGNAL IS PRESENT FROM A DEVICE CONNECTED TO THE CLOSE INPUT TERMINAL	
STOP		STOP INPUT TERMINAL IS OPEN AND NOT CONNECTED TO COMMON	
PROGRAM			CONTROLLER IS IN PROGRAMMING MODE
REVERSE	DELAY SET		SET REVERSE DELAY TIME
LOCKOUT	ALARM SET	CONTROLS AND OPERATOR ARE LOCKED OUT BECAUSE OF EXISTING TROUBLE CONDITION	
RADIO	LEARN	BUILT-IN RECEIVER IS DETECTING A RADIO SIGNAL FROM A REMOTE CONTROL	TRANSMITTERS CAN BE ENTERED INTO MEMORY (UP TO 40 TRANSMITTERS)
OPEN CURRENT			
OPEN/RESET		OPEN/RESET INPUT ACTIVATED BY LOOP OR SWITCH	
OPEN RELAY		OPEN RELAY IS ACTIVATED	
OPEN LIMIT	BRAKE DELAY	OPEN LIMIT SWITCH IS ACTIVATED	
CLOSE CURRENT	SET	MOTOR CURRENT HAS EXCEEDED THE CLOSE CURRENT SETTING WHILE CLOSING	SET MAXIMUM CLOSE CURRENT
CLOSE OBSTR	MGT 1 SET	CLOSE OBSTRUCTION TERMINAL CONNECTED TO COMMON BY BEAM OR SAFETY EDGE, OR SIGNAL FROM MGT OBSTACLE TRANSMITTER	SET MGT #1 FUNCTION
CLOSE RELAY	AUTO CLOSE SET	CLOSE RELAY IS ACTIVATED	SET AUTO-CLOSE TIME
CLOSE LIMIT	AC DC SET	CLOSE LIMIT SWITCH IS ACTIVATED	SET MOTOR TYPE
SINGLE	SET	SINGLE TERMINAL CONNECTED TO COMMON BY AN EXTERNAL PUSHBUTTON OR RADIO	SET SINGLE BUTTON INPUT FUNCTION
MAX RUN	SET	MAXIMUM RUN TIMER HAS BEEN EXCEEDED	SET MAXIMUM RUN TIME
COMM LINK	SET	DUAL OPERATOR CONNECTION DETECTED, BLINKS IF CONNECTION HAS FAILED	
MAINT ALERT	SET	MAINTENANCE IS REQUIRED ON OPERATOR	SET MAINTENANCE ALERT CYCLE COUNT

## APEX FUNCTION DISPLAY INDICATIONS

"RL" LEFT OR RIGHT HAND OPERATION	"SB" SINGLE BUTTON INPUT SETUP	"SS" SOFT START/STOP DURATION	"TD" DELETE TRANSMITTERS
"PM" SINGLE OR DUAL GATE	"SM" STAGGER MODE	"CT" RESET CYCLE COUNT	"ML" LEARN MGT TRANSMITTERS
"AC" AUTO CLOSE TIMER	"ST" STAGGER TIME	"MA" MAINTENANCE ALERT TRIGGER	"MD" ERASE MGT TRANSMITTERS
"RP" RUN ALARM PRE-START ALARM	"AR" AUXILIARY RELAY MODE	"OR" OPEN/RESET INPUT	"MO" MOTOR TYPE SELECTION
"CC" MAXIMUM CLOSE CURRENT	"RD" REVERSE DELAY TIME	"TG" ANTI TAILGATE	"CL" RESET TO FACTORY DEFAULTS
"AD" ADVANCED PROGRAMMING	"LP" LOW POWER MODE	"RA" RADIO ENABLE	
"RT" MAXIMUM RUN TIMER	"FS" POWER FAILURE MODE	"TL" LEARN TRANSMITTERS	

## Terminal Descriptions

TERMINAL	GROUP	FUNCTION
AC N AC	24 VOLT INPUT	FACTORY CONNECTED TO 24 VAC FROM TRANSFORMER OR 24 VDC FROM CONTINUOUS DUTY DC SUPPLY.
DC - DC +	ACCESSORY POWER	PROVIDES 24 VOLT DC POWER FOR ACCESSORIES. (.5A MAX)
RESET COMMON	RESET BUTTON	NOT USED IN BARRIER GATES.
C B A	COMM LINK	FOR 3-WIRE NETWORK CONNECTION TO SECOND OPERATOR IN DUAL GATE INSTALLATIONS.
COMMON SINGLE	SINGLE BUTTON INPUT	CONNECT TO NORMALLY OPEN SWITCH FOR SINGLE BUTTON OPERATION. ALTERNATES BETWEEN OPEN-CLOSE OR OPEN-STOP-CLOSE DEPENDING ON PROGRAMMING.
COMMON FIRE DEPT	FIRE BOX INPUT	CONNECT TO NORMALLY OPEN SWITCH IN FIRE BOX FOR FIRE DEPARTMENT ACCESS.
COMMON OPEN	OPEN INPUT	CONNECT TO NORMALLY OPEN DEVICES (KEYPAD, CARD READER, KEYSWITCH, TELEPHONE ENTRY SYSTEM) TO OPEN THE GATE. A CONSTANT OPEN INPUT WILL HALT THE AUTO CLOSE TIMER UNTIL RELEASED.
OPEN CLOSE COMMON STOP	3-BUTTON STATION INPUT	CONNECT TO 3-BUTTON STATION FOR OPEN-CLOSE-STOP CONTROL. A CONSTANT OPEN INPUT WILL OVERRIDE THE MID-TRAVEL STOP AND HALT THE AUTO CLOSE TIMER UNTIL RELEASED.
COM OPEN/RESET	OPEN/RESET INPUT	PROGRAMMABLE FOR STANDARD RESET LOOP, OPEN COUNTER MODE USING THE SHADOW/RESET LOOP, OR OPEN SUPERVISED MODE. SEE PAGE 15.
C-OBS COM	CLOSE OBSTRUCTION INPUT	CONNECT TO NORMALLY OPEN DEVICES (GATE EDGE, PHOTO BEAM) TO DETECT AN OBSTRUCTION DURING CLOSING. WHILE GATE IS MOVING, ANY CLOSE OBSTRUCTION SIGNAL WILL CAUSE THE GATE TO STOP, THEN REVERSE AND TRAVEL TO THE FULL OPEN POSITION. SHOULD A OPEN OBSTRUCTION INPUT OR AN OPEN DIRECTION INHERENT ENTRAPMENT CONDITION OCCUR PRIOR TO THE GATE REACHING THE OPEN LIMIT, THE OPERATOR WILL LOCKOUT AND SOUND THE CONTINUOUS TONE ALARM. IF THE AUTO CLOSE TIMER IS SET, WHEN THE CLOSE OBSTRUCTION INPUT IS CLEARED, THE GATE WILL CLOSE WHEN THE AUTO CLOSE TIMER EXPIRES.
COM REV	REVERSE	CONNECT TO NORMALLY OPEN DEVICES TO CAUSE A REVERSAL WHEN THE GATE IS TRAVELING CLOSED. THE GATE WILL REVERSE TO THE FULL OPEN POSITION. <b>TYPICALLY NOT USED IN BARRIER GATES.</b>
OPEN LOOP OPEN LOOP	OPEN LOOP	CONNECT TO OPEN LOOP/FREE EXIT LOOP. THE GATE WILL OPEN WHEN THE LOOP IS TRIGGERED, AND REMAIN OPEN AS LONG AS THE LOOP IS TRIGGERED. REQUIRES LOOP DETECTOR.
REVERSE LOOP REVERSE LOOP	REVERSE LOOP	CONNECT TO REVERSE LOOP. TRIGGERING THE LOOP WILL CAUSE A REVERSAL WHEN THE GATE IS TRAVELING CLOSED. THE GATE WILL REVERSE TO THE FULL OPEN POSITION. REQUIRES LOOP DETECTOR. <b>TYPICALLY NOT USED IN BARRIER GATES.</b>
SHADOW/RESET LOOP SHADOW/RESET LOOP	SHADOW/RESET LOOP	CONNECT TO RESET LOOP TO KEEP THE GATE IN ITS FULLY OPEN POSITION AS LONG AS THE SIGNAL IS PRESENT. USED TO KEEP GATE OPEN WHILE VEHICLE IS PASSING THROUGH. REQUIRES LOOP DETECTOR. <b>ALSO USED FOR OPEN COUNTER MODE IN BARRIER GATES.</b>
- +	ALARM	NOT USED IN BARRIER GATES.
N.O. COM N.C.	AUX RELAY	FOR CONNECTION TO AUXILIARY DEVICES (MAGNETIC LOCK, SOLENOID LOCK, STROBE LIGHT) FOR ACTIVATION (OR DEACTIVATION) DURING GATE OPERATION.
+ -	24 VOLT SOLAR PANEL	FOR CONNECTION TO 24 VOLT SOLAR PANEL FOR BATTERY CHARGING.
+ -	24 VOLT BATTERY	FACTORY CONNECTED TO BATTERIES IN DC MODEL OPERATORS.

# Operator Accessory Connections

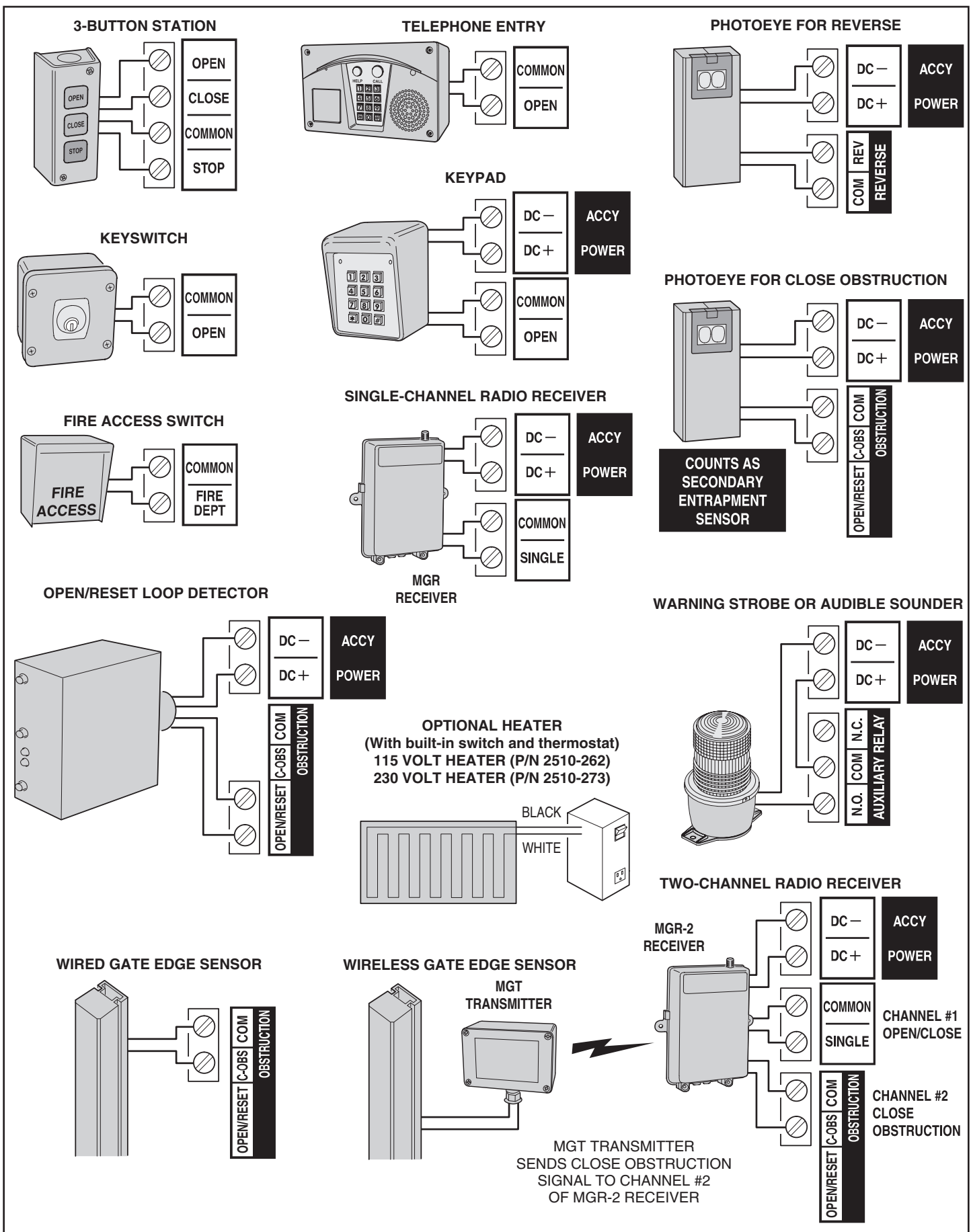

Figure 10. Operator Accessory Connections

# Basic Controller Programming

## Programming Overview

The Controller can be programmed with various options for the operator. The programming fields are defined as “functions” that have “options”. To make setup easier for the installer, the Controller’s programming is divided into two groups: basic and advanced. The basic programming group contains the functions commonly used in most swing gate installations. The advanced programming group contains functions less commonly used (i.e. dual gate stagger delay, maximum run timer, etc.).

## Entering Programming Mode

Enter programming mode by pressing the **UP** and **DOWN** buttons together for one second. While in programming mode the **PROGRAM** indicator will light.

## Exiting Programming Mode

Exit programming mode at any time by pressing the **UP** and **DOWN** buttons together. The Controller will automatically exit programming mode after three minutes of inactivity.

## Programming Keystrokes

### (Typical Programming Method)

While in programming mode, press the **UP** or **DOWN** buttons to scroll through the programming functions. When the desired function is displayed press the **ENTER** button to display the currently set option for the function.

**When an option is displayed, the decimal points are lit.**

To change the option, press and hold the **ENTER** button for 1 second. To indicate that an option is ready to be changed, the display will flash. While the display is flashing, press the **UP** or **DOWN** button to display the other options available for that function.

When the desired option is displayed, press the **ENTER** button to store it into memory. To select another function, press **ENTER, UP,** or **DOWN.**

## Left or Right Hand Operation

The function is not used with barrier gates.

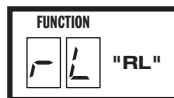

## Dual Gate Enable

The factory default is for single gate operation. For dual gate operation, wire the two gate controllers together through the **COMM LINK** terminals (see Page 19) and enable dual gate operation with this programming step.

## Auto Close Timer

The factory default turns off the Auto Close Timer. The timer can be set from 1 to 59 seconds and from 1 to 9 minutes. When the Auto Close Timer is set, after opening, the gate will wait for the length of the Auto Close Timer then close automatically.

## Run Alarm and Pre-start Alarm

The function is not used with barrier gates.

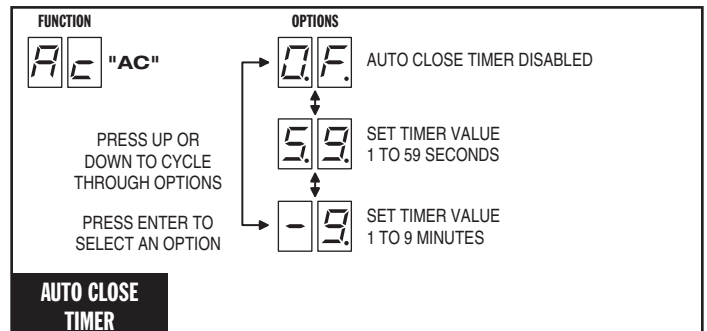
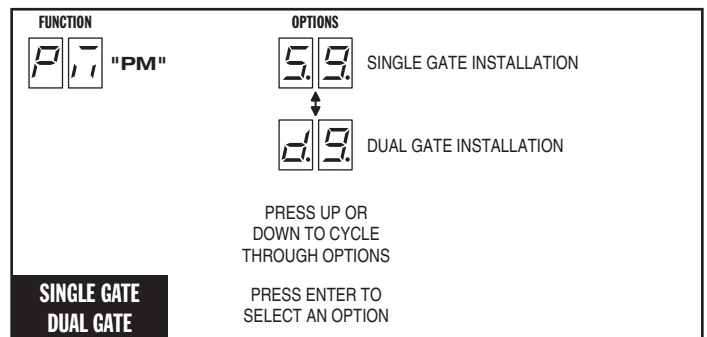
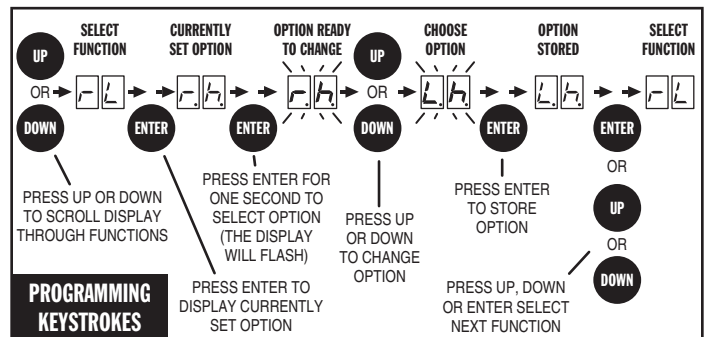
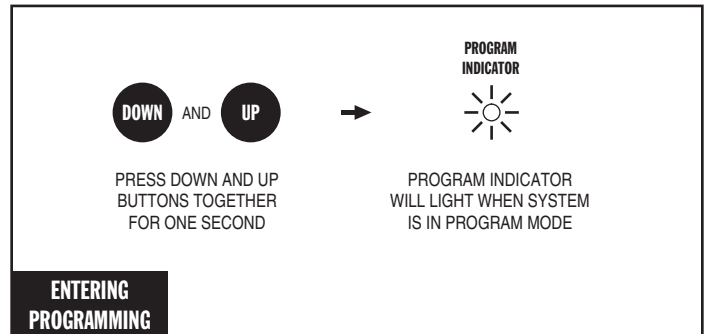

## Basic Controller Programming (Cont.)

### Maximum Close Direction Current Setting

To detect obstacles or mechanical problems with the gate, the operator can monitor its motor current. If the close current load exceeds the programmed maximum load range number, the gate arm will stop, reverse, and travel to the full open position. Another close request will be required to start the operator again. If after restart, the overload or a close obstacle happens again before the close limit is reached, the operator will lockout and activate the alarm output. If the auto close timer is set, when the close obstruction input is cleared, the gate arm will close when the auto close timer expires.

**The factory default setting of "OF" disables the close direction current sensing for the operator. The maximum close direction current setting can be adjusted using the following procedure:**

Using the + and - buttons, set the programmed range number so that a minimal force will activate a reversal should an obstruction occur, but high enough to keep the gate arm operating under normal conditions without interruption.

## Advanced Controller Programming

### Entering Advanced Programming Mode

To access and program the Advanced Programming functions, for each programming session, Advanced Programming must be enabled.

**After exiting programming, the Advanced Programming functions will be available on the programming display during the next programming session unless the operator has run 50 or more cycles. After that, Advanced Programming must be enabled again.**

### Maximum Run Time

The factory default for the Maximum Run Time (MRT) is 10 seconds. When the operator starts, a timer will begin counting. If an open or close limit is not reached or an obstacle or reversing input is not received before the timer expires, the operator will stop, the unit locks out and the alarm sounds. The timer can be set for 10 to 99 seconds, but should be left at 10 seconds in most applications. Setting it too close to the actual run time may cause the time to expire with changing ambient temperature, gate conditions, etc...

If AC is present and an open or close limit is not reached or an obstacle or reversing input is not received before this timer exceeds MRT, the operator will stop, the unit locks out and the alarm sounds.

In the case that AC is not present and MRT expires, it will be ignored as long as the actual run time is under 10 seconds. When the gate reached full open or full close position, MRT will be interpreted as fail safe/secure. EN05 will occur. If FS as set to fail safe, the gate will open. If FS is set to fail secure, the gate will close. However, if the actual run time is higher than 10 seconds, it will be interpreted as a physical mechanical problem, EN01 will occur and the gate will stop immediately.

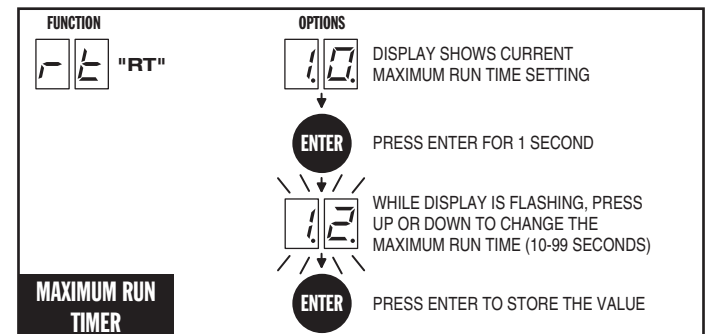
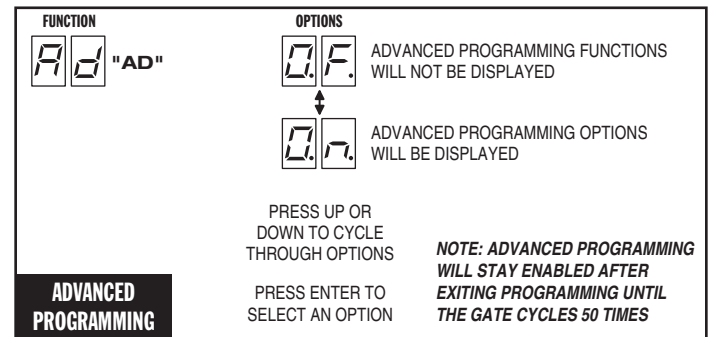
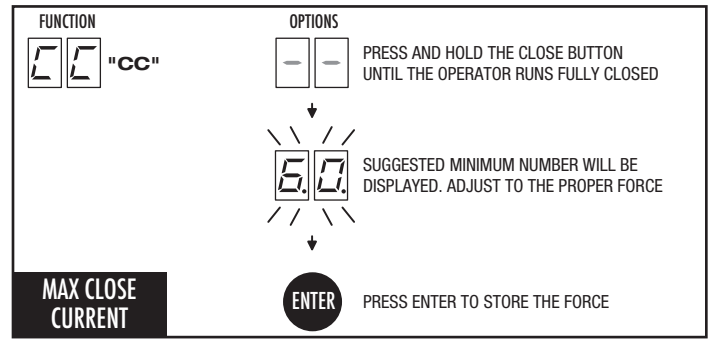



## Advanced Controller Programming (Cont.)

### Single Button Input Setup

This function is used for selecting the operation for single button controls and radio receivers.

The factory default sets the **SINGLE** input terminal so successive inputs will cycle the operator in OPEN-STOP-CLOSE-STOP order.

Alternately, the **SINGLE** input can be set to cause the gate to OPEN unless the gate is fully open. If the gate is closing, the input will cause the gate to reverse. If the gate is fully open, the input will cause the gate to CLOSE.

### Stagger Mode

This function is not used in dual barrier gate installations.

- ✓ **NOTE:** This function will only be displayed if dual gate operation is selected.



### Stagger Delay Time

This function is not used in dual barrier gate installations.

- ✓ **NOTE:** This function will only be displayed if dual gate operation is selected.

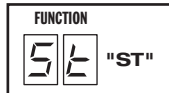

### Auxiliary Relay Mode

The Auxiliary Relay has normally open and normally closed contacts. The factory setting disables the Auxiliary Relay. The relay can be set for:

- **Maglock:** To deactivate a magnetic or solenoid gate lock, the relay will energize during any pending or actual gate motion (open only).
- **M4:** To deactivate a magnetic or solenoid gate lock, the relay will energize during any pending or actual gate motion (open only). 3 seconds after the gate starts to move, the relay will de-energize. This option is used for higher current solenoid locks.
- **Ticket Dispenser:** The relay will energize while the gate is moving in the open direction and at the full open limit, or in an entrapment condition.
- **Strobe:** To activate a warning strobe light, the relay will energize during any pending or actual gate motion (either open or close).
- **Alarm:** The relay will energize if the gate is manually forced open from the full closed position.

### Reverse Delay Time

The factory default sets the Reverse Delay to 0 seconds. The operator will wait the length of the delay before reversing direction. This feature will not change the reversal time when the operator is responding to an entrapment condition from an obstruction input or inherent entrapment protection sensor. The Reverse Delay can be set from 0 to 9 seconds. Heaver gates require a longer delay to allow time for the gate to stop. The Reverse Delay is active when the gate first stops on either limit or in between limits.

FUNCTION	OPTIONS
SB "SB"	05 SINGLE INPUT WILL CYCLE OPERATOR IN ORDER OF OPEN-STOP-CLOSE-STOP
	00 SINGLE INPUT WILL OPEN OPERATOR, IF OPERATOR IS ALREADY OPEN, SINGLE INPUT WILL CLOSE OPERATOR

PRESS UP OR DOWN TO CYCLE THROUGH OPTIONS

PRESS ENTER TO SELECT AN OPTION

**SINGLE BUTTON INPUT SETUP**

FUNCTION	OPTIONS
AR "AR"	0F AUXILIARY RELAY DISABLED
	1L AUXILIARY RELAY USED FOR MAGLOCK CONTROL
	14 AUXILIARY RELAY USED FOR MAGLOCK OR SOLENOID CONTROL 3 SECOND DELAY TO RE-ENERGIZE
	6d AUXILIARY RELAY USED FOR TICKET DISPENSER CONTROL
	5L AUXILIARY RELAY USED FOR WARNING STROBE LIGHT
	AL AUXILIARY RELAY USED FOR CONNECTION TO ALARM DEVICE

PRESS UP OR DOWN TO CYCLE THROUGH OPTIONS

PRESS ENTER TO SELECT AN OPTION

**AUXILIARY RELAY MODE**

FUNCTION	OPTIONS
rd "RD"	00 SET TIMER VALUE 0 TO 9 SECONDS

PRESS UP OR DOWN TO CYCLE THROUGH OPTIONS

PRESS ENTER TO SELECT AN OPTION

**REVERSE DELAY TIME**

## Advanced Controller Programming (Cont.)

### Low Power Mode

This function is only used with DC barrier gate Model SG-D. The factory default disables the Low Power Mode. When Low Power Mode is enabled, and AC power fails, the controller will assume Low Power Mode after 60 seconds of gate inactivity. Low power mode turns off all accessory power and indicators. Only inputs from the radio receiver, reverse loop, open loop (optional by programming), fire department input, or restoring AC power will wake the Controller from Low Power Mode. Programming Mode can still be accessed while the Controller is awake in Low Power Mode.

✓ **NOTE:** This function will only be displayed in Model SG-D operators.

### Power Failure Mode

This function is only used with DC barrier gate Model SG-D. The factory default is set for Fail Safe, alternately the Controller can be set for Fail Secure, Open Immediate, or Close Immediate.

- **Fail Safe:** If the AC power fails and the battery voltage drops below approximately 22 Volts, 5 seconds later the operator will cycle open if not already open. When AC power is restored, or the battery gets charged by solar panels, the operator will resume normal operation and auto-close if programmed to do so.
- **Fail Secure:** If the AC power fails and the battery voltage drops below approximately 22 Volts, 5 seconds later the operator will cycle closed if not already closed. When AC power is restored, or the battery gets charged by solar panels, the operator will resume normal operation.

✓ **NOTE:** Fail Safe and Fail Secure are disabled if Stagger Mode is enabled.

- **Open Immediate:** If the AC power fails, the operator will cycle open if not already open and cease operation. When AC power is restored, the operator will resume normal operation and auto-close if programmed to do so.
- **Close Immediate:** If the AC power fails, the operator will cycle closed if not already closed and cease operation. When AC power is restored, the operator will resume normal operation.

✓ **NOTE:** This function will only be displayed in Model SG-D operators.

### Soft Start/Stop Duration

This function is only used with DC barrier gate Model SG-D. This function causes the operator to start and stop the DC motor slowly reducing gate wear and tear (at the full open or closed positions only). The factory default sets the Soft Start/Stop Duration to 3 seconds. The Soft Start/Stop Duration can be set from 1 to 10 seconds.

✓ **NOTE:** Changing the Soft Start/Stop Duration will reset the open and close current setting value to zero. It will be necessary to reprogram maximum open and close current settings.

✓ **NOTE:** This function will only be displayed in Model SG-D operators set for DC motor operation with soft start motor selection.

### Reset Cycle Count

The Controller counts of the number of times the operator has been cycled full open and close. The cycle count can be displayed. The display will scroll the cycle count number, flashing two digits at a time from left to right.

To reset the Cycle Count, press and hold the **ENTER** button for 2 seconds while the Cycle Count is displayed.

If the Maintenance Alert has been triggered, resetting the Cycle Count will also reset the Maintenance Alert indicator.

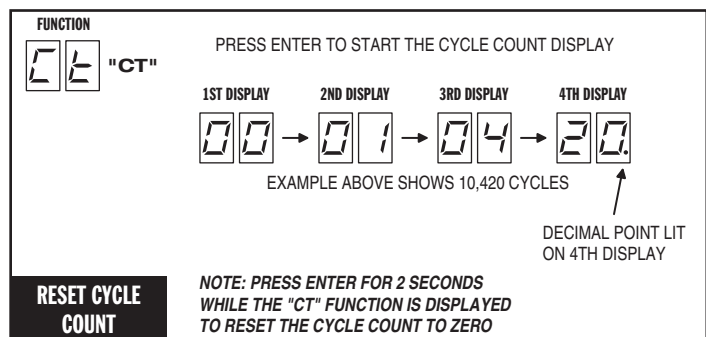
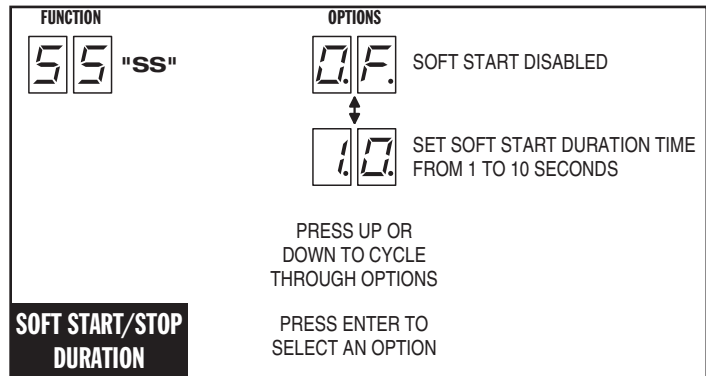
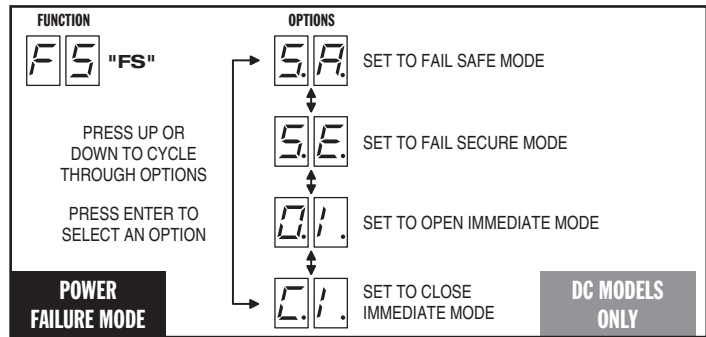
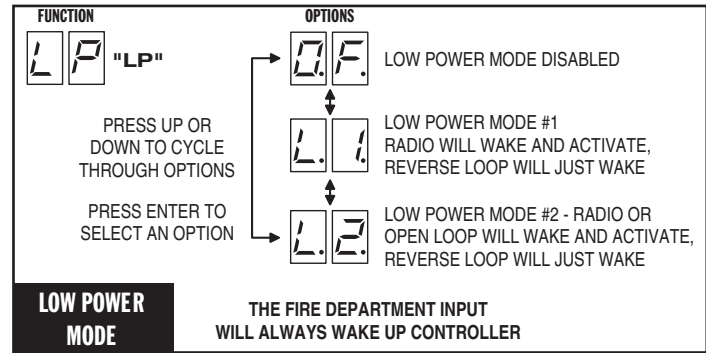

## Advanced Controller Programming (Cont.)

### Maintenance Alert Trigger

The Controller has a **MAINT ALERT** indicator that can be programmed to light when the number of activations exceeds a set number of cycles.

The factory default sets the Maintenance Alert Trigger to 10,000 cycles. The Maintenance Alert Trigger can be programmed for 5, 10, 15, or 25 thousand cycles.

The Maintenance Cycle Count can be reset independently from the operator's absolute Cycle Count.

### Open/Reset Input

✓ **NOTE:** For use in single gate installations only.

The Controller can be programmed to partially or fully open the gate with an **OPEN/RESET** input, or to count the number of open commands and leave the gate open until an equal number of **SHADOW/RESET** loop triggers occur.

The **OPEN/RESET** terminals can connect to a loop detector or normally open switch (see accessory wiring in Figure 10 on Page 10). The **SHADOW/RESET** loop uses a plug-in loop detector.

The factory default is setting is Off (**OF**).

- **OF Open Mode Off:** The **OPEN/RESET** input acts as a standard **RESET** loop and holds the gate arm open as long as a vehicle is on the loop. If the gate arm **is opening or fully open** when the vehicle **exits** the loop, the gate arm will close.
  - **CT Open Counter Mode:** The Controller can count and remember the number of open commands received, and will count the same number of **SHADOW/RESET** loop triggers before the gate will close.
- ✓ **NOTE:** Set the Auto Close Timer to OFF when using the CT option.
- **SU Open Supervised Mode:** The **OPEN/RESET** input opens the gate arm **fully** on the initial command. **Once open**, the arm will close on the removal of the command.

### Anti-tailgate

The Controller can be programmed to have the barrier gate arm prevent "tailgating" when a second vehicle attempts to drive through closely following a prior vehicle that has been granted access.

The factory default disables this feature. If the **SHADOW/RESET** loop is activated while the gate arm is closing, the gate arm will stop. When anti-tailgate is enabled, the **SHADOW/RESET** loop will be ignored once the arm begins traveling downward.

### Radio Enable

The Controller contains a built-in MegaCode® radio receiver to allow activation from up to 40 access control transmitters and two Model MGT (gate edge) transmitters. The factory default enables the internal radio receiver. Alternately, the internal receiver can be disabled.

### Antenna Installation

A local whip antenna is included for use with the operator as a remote antenna. If using a remote antenna, connect coax cable from the antenna to the **ANTENNA** connector.

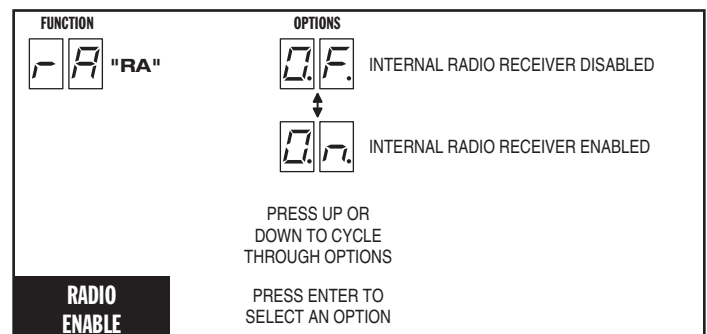
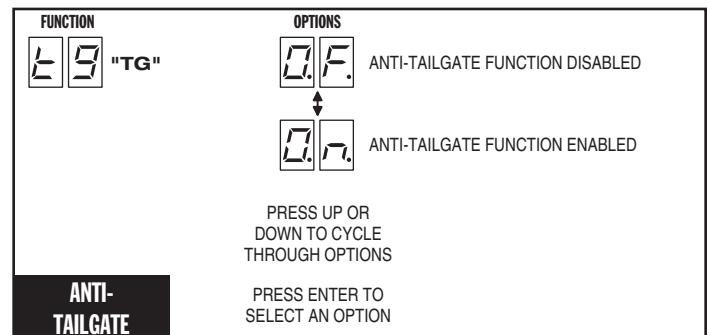
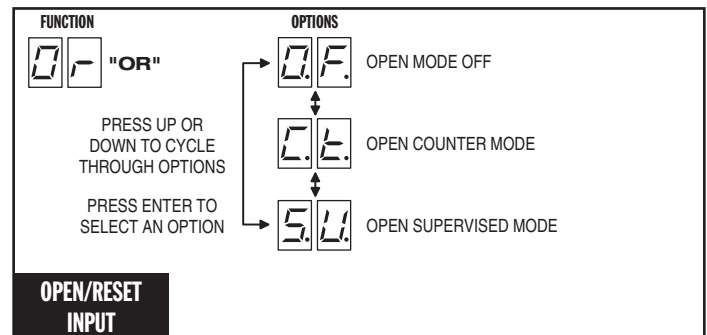
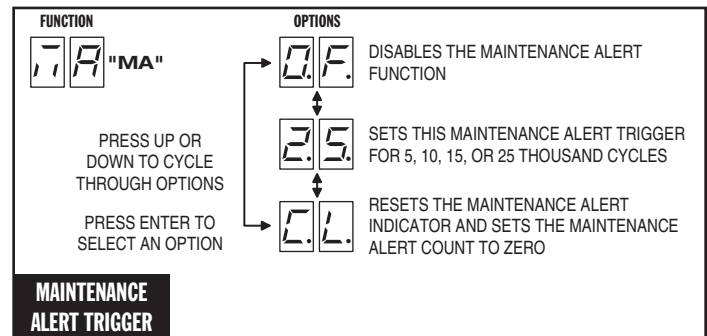

## Advanced Controller Programming (Cont.)

### Radio Transmitter Learn

The Controller's built-in MegaCode® radio receiver can store the IDs of up to 40 transmitters. Refer to the figure for the steps required to learn transmitters.

- ✓ **NOTE:** This function will NOT be displayed if the transmitter memory is full, or if the radio receiver is disabled.

### Radio Transmitter Delete

Transmitters can be deleted from the Controller's memory either individually, or all at the same time. Refer to the figure for the steps required to delete transmitters.

- ✓ **NOTE:** This function will NOT be displayed if no transmitters are stored in memory, or if the radio receiver is disabled.

### MGT Obstacle Transmitter Learn

The Controller supports one or two Model MGT Obstacle Transmitters. The transmitters can be programmed to function as Open Obstruction, Close Obstruction, Reverse, or Stop. Refer to the figure for the steps required to learn MGT transmitters.

- ✓ **NOTE:** This function will NOT be displayed if two MGT transmitters are already stored in memory, or if the radio receiver is disabled.

### MGT Obstacle Transmitter Delete

MGT transmitters can be deleted from the Controller's memory either individually, or all at the same time. Refer to the figure for the steps required to delete MGT transmitters.

- ✓ **NOTE:** This function will NOT be displayed if no MGT transmitters are stored in memory, or if the radio receiver is disabled.

### Motor Type Selection

The factory sets the default for the Controller to match the type of motor in the operator. If required, change the motor selection option to a different type of motor used in the operator. The only two options used for barrier gates are:

- **Ac** - AC Motor
- **d2** - DC Motor with Electronic Soft Start/Stop

### Reset Controller to Factory Defaults

The Controller can be reset with this function. **ALL PROGRAMMED DATA WILL BE LOST**, and the factory defaults will be loaded. This function will not erase radio transmitters, current sense values, or motor type. Transmitters must be deleted with the two functions above.

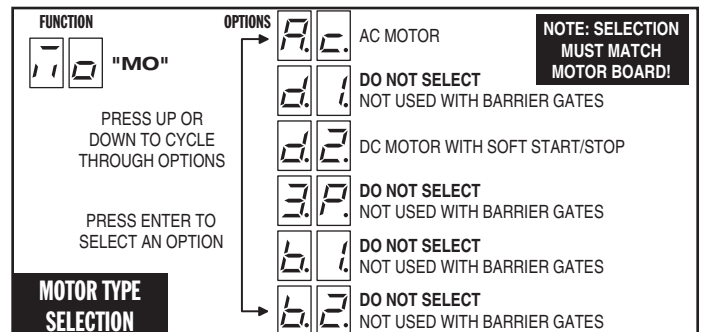
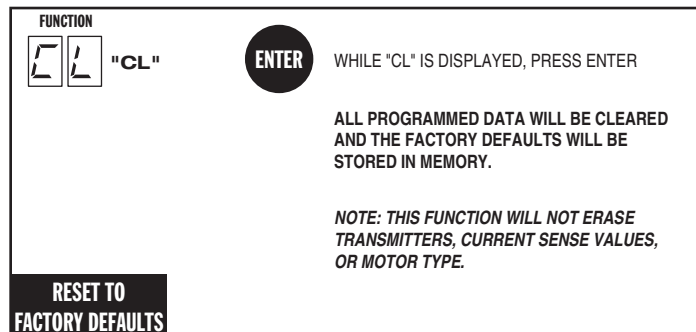
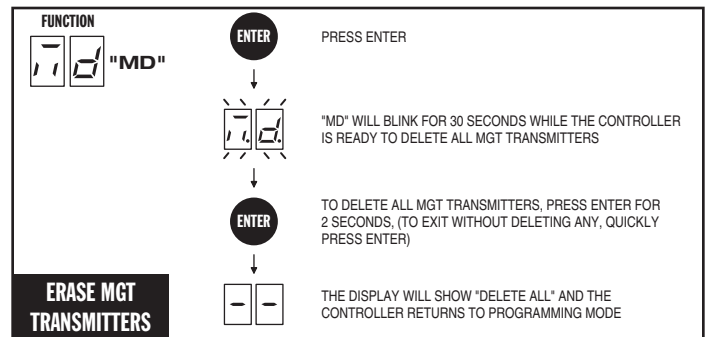
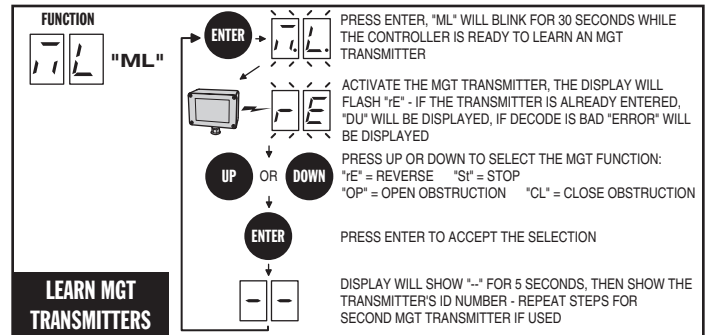
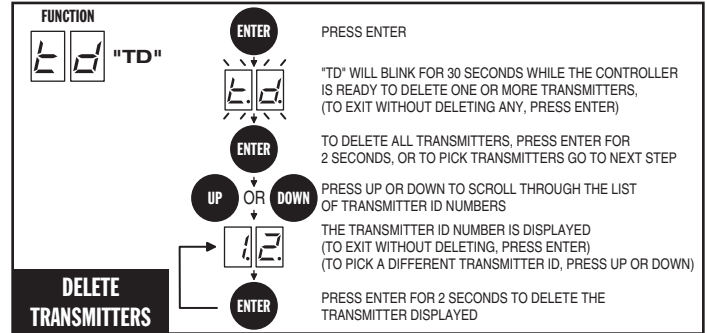
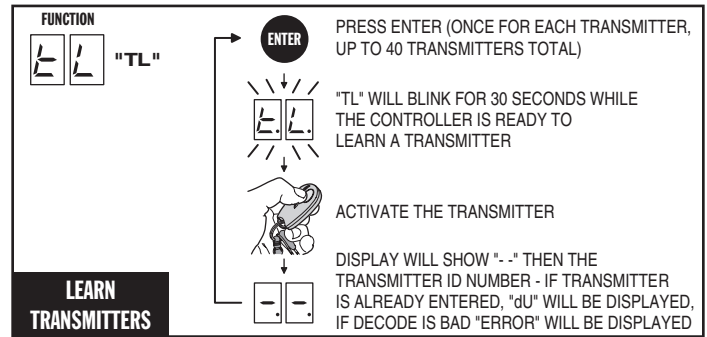

# Free Gate Loop Layout Illustration

THIS SYSTEM IS TYPICALLY USED AS AN ENTRANCE OR EXIT IN CONJUNCTION WITH A CONTROLLED ENTRANCE OR EXIT.

**OPERATION OF FREE GATE SYSTEM:**

WHEN VEHICLE PASSES OVER OPEN DETECTOR LOOP, THE ARM RAISES.

WHEN VEHICLE PASSES OVER AND OFF OF RESET DETECTOR LOOP, THE ARM LOWERS.

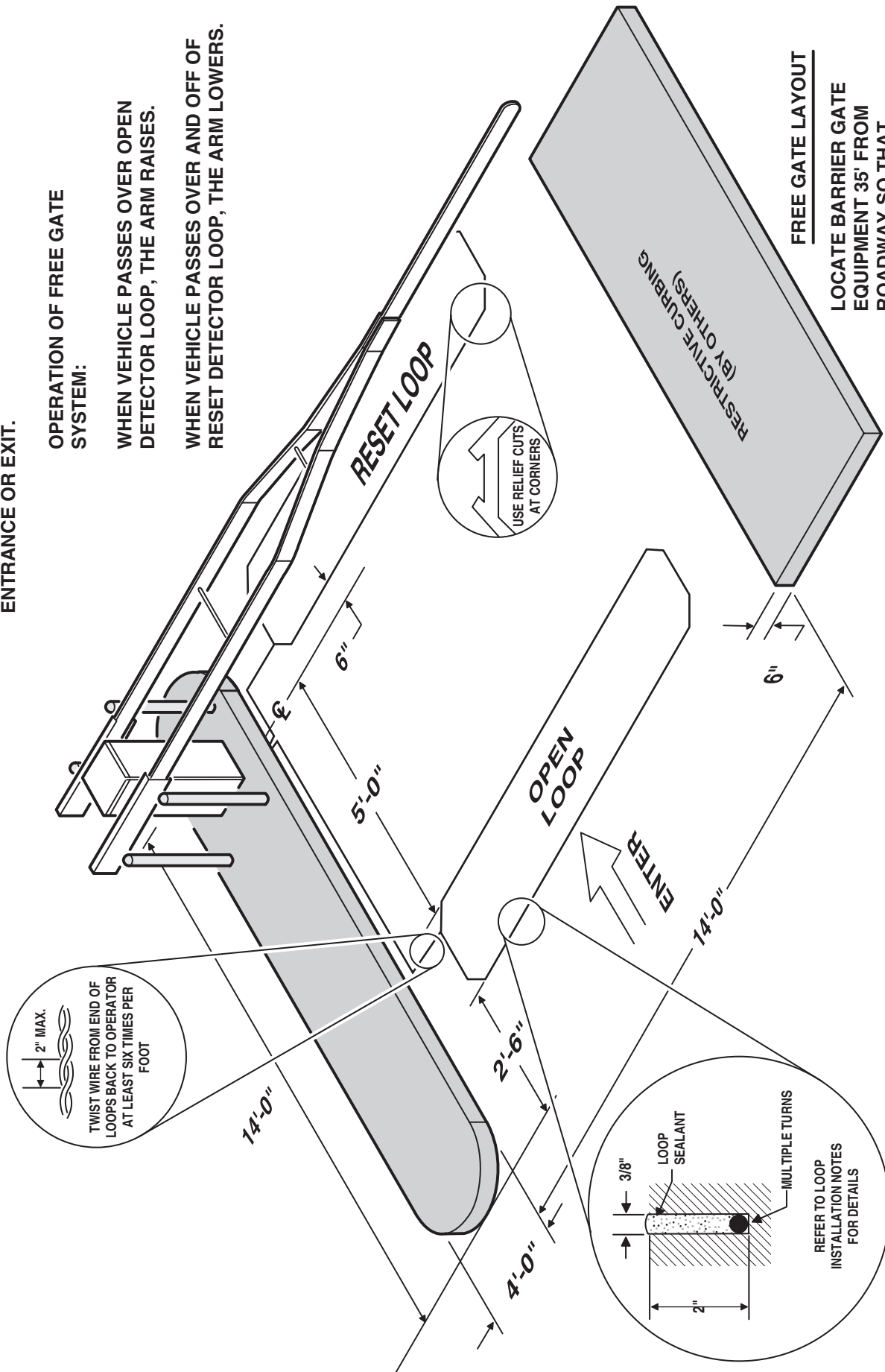

**FREE GATE LAYOUT**  
 LOCATE BARRIER GATE EQUIPMENT 35' FROM ROADWAY SO THAT APPROACHING VEHICLES ARE ABLE TO COMPLETE RIGHT TURN BEFORE REACHING ACTUATING DEVICE.

REFER TO LOOP INSTALLATION NOTES FOR DETAILS



# Pay Gate Loop Layout Illustration

## PAY GATE LAYOUT

LOCATE BARRIER GATE EQUIPMENT 35' FROM ROADWAY SO THAT APPROACHING VEHICLES ARE ABLE TO COMPLETE RIGHT TURN BEFORE REACHING ACTUATING DEVICE.

## OPERATION OF PAY GATE SYSTEM:

WHEN DRIVER INSERTS CARD INTO CARDLOCK, KEY INTO KEYLOCK, ETC., THE GATE ARM WILL RAISE TO ALLOW PASSAGE OF THE VEHICLE.

WHEN VEHICLE PASSES OVER AND OFF RESET DETECTOR LOOP, THE GATE ARM WILL LOWER.

THIS SYSTEM IS SUITABLE FOR DAILY, MONTHLY, OR PREFERRED PARKING AND IS WIDELY USED BY HOSPITALS, MEDICAL CLINICS, UNIVERSITIES, OFFICE BUILDINGS, FACTORIES, ETC., WHEN THERE IS NEED FOR CONTROLLED PARKING.

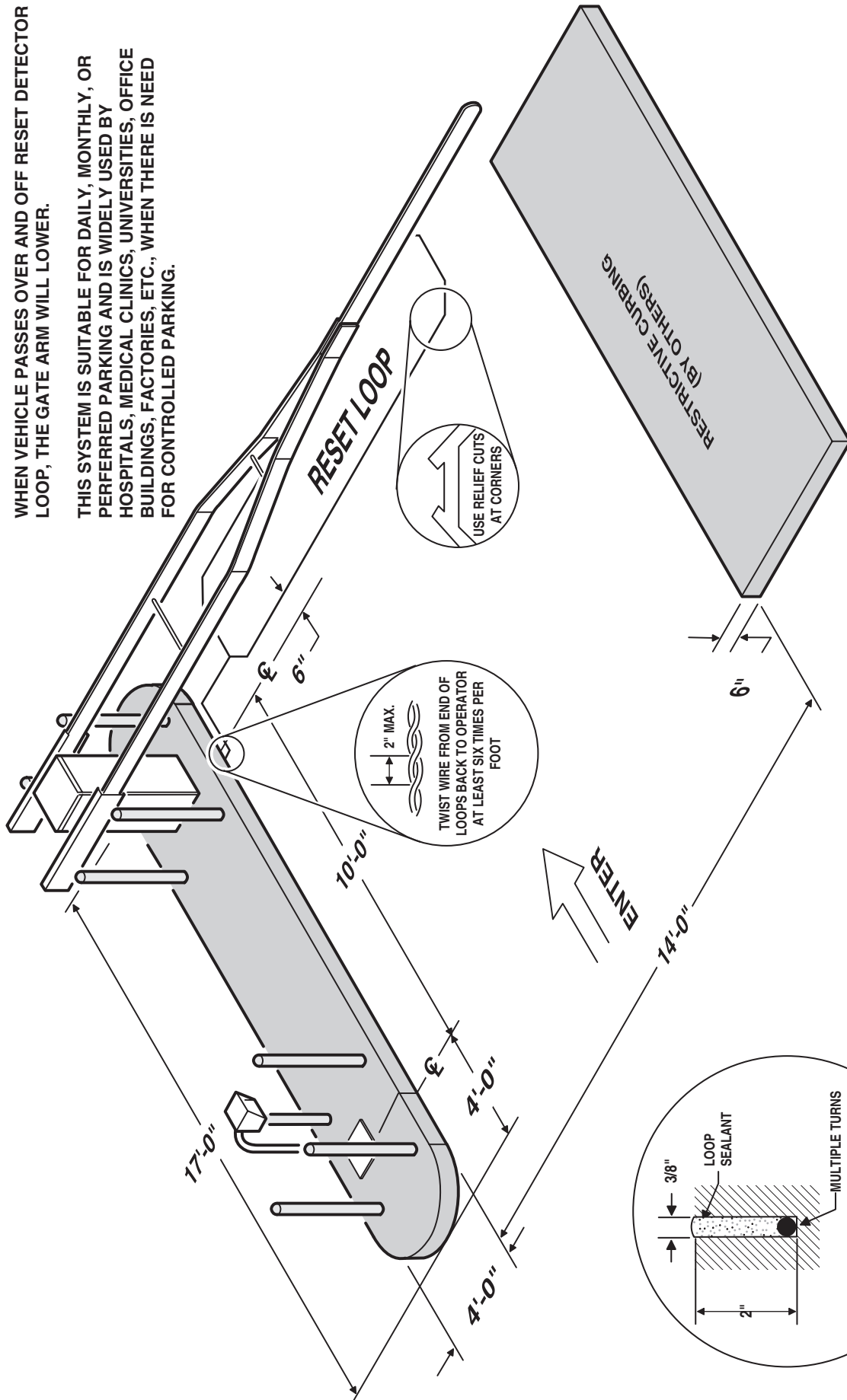



## Dual Gate Installations

Two operators can be used in dual gate installations. The operators communicate with each other through the 3-wire **COMM LINK** terminals.

When one operator activates, the **COMM LINK** connection signals the other operator to activate. Each operator functions independently, controlling its gate and monitoring its inputs and accessories.

A three-wire shielded conductor cable is required to connect two operators together for dual operation. Use Belden 8760 Twisted Pair Shielded Cable (or equivalent) only – P/N 2500-1982, per foot).

✓ **NOTE:** The shield wire should be connected COMM LINK terminal “C” in both operators.

Three of the programming functions available are only used for dual gate installations:

- **Dual Gate Enable**  
Dual Gate Enable must be set for all dual gate installations.
- **Stagger Mode (Typically not used with barrier gates)**  
The Stagger Mode function determines if the operator has a delayed open or a delayed close. In dual swing gate installations, typically one operator is programmed for delayed open, and the other operator is programmed for delayed close.
- **Stagger Delay Time (Typically not used with barrier gates)**  
The Stagger Time sets the length of the delay for the Stagger Mode.

See Pages 11 & 13 for details on these three dual gate programming functions.

Set the following parameters in each gate operator individually in a single gate mode before connecting the network cable and operating in dual gate mode.

1. Open and Close Limit settings
2. Open and Closed direction inherent entrapment protection (OC & CC)

After these parameters have been set, and each operator has been tested independently and is functioning correctly in single gate mode, then set BOTH operators to dual gate (dg) in the Paired Mode setup step under

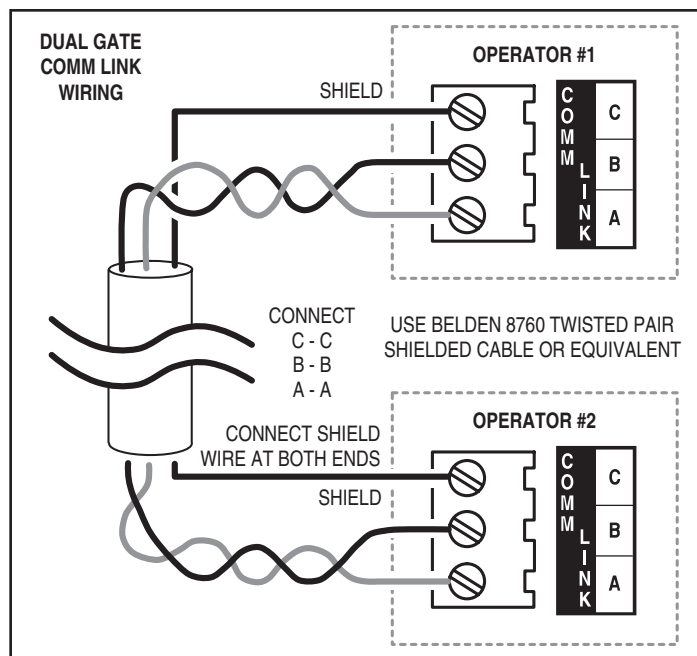

Figure 11. COMM LINK Wiring

Basic Programming steps.

## Gate Operation

### Open Button

Opens the gate. If the Auto Close Timer is set, it will be suspended until the **OPEN** button is released.

### Close Button

Closes the gate if the gate is open. Also closes the gate if the gate is in the process of opening.

### Stop Button

Stops the gate from opening or closing at any time.

### Single Input

Opens the gate if it's closed and closes the gate if it's open (open-close programming option). Activating the input while the gate is moving will reverse the gate.

Can be programmed to stop the gate while the gate is moving (open-stop-close programming option).

### Fire Department Input

Fully opens the gate when the input is activated. Overrides the Mid-travel Stop and Auto Close Timer (if either is programmed for the gate). The gate will lockout in the open position without sounding the alarm. Press the **STOP** button to release the lockout.

### Open Input

Functions the same as the **OPEN** button.

### Open/Reset Input

Programmable for standard reset loop, Open Counter Mode, or Open Supervised Mode. See Page 15.

### Close Obstruction Input

While the gate is closing, any close obstruction signal will cause the gate to stop, reverse, and travel to the full open position. Should a open obstruction input or an open direction inherent entrapment condition occur prior to the gate reaching the open limit, the operator will lockout and sound the continuous tone alarm. Another close request will be required to start the operator again. If after restart, the overload or a close obstacle happens again before the close limit is reached, the operator will lockout and sound the alarm. If the auto close timer is set, when the close obstruction input is cleared, the gate will close when the auto close timer expires.

### Reverse Input

If the reverse input is triggered while the gate is closing, the gate will reverse to the full open position. If the Auto Close Timer is set, when the reverse input is cleared, the gate will close when the Auto Close Timer expires. **Not typically used with barrier gates.**

### Open Loop

Functions the same as the **OPEN** button.

### Reverse Loop

Functions the same as the reverse input. **Not typically used with barrier gates.**

### Reset Loop

Holds the gate fully open while triggered.

## Operation Indications

During normal operation, the Controller's displays will indicate current operating conditions and status.

### Power-up Display

When the Controller powers up, dashes will show on the display, then the firmware version number, then the gate type (**bg** for barrier gates).

Exiting programming restarts the Controller. The power-up display will show upon the restart.

### Idle Condition

While the Controller is idling, waiting for a command, the display will show circulating dashes.

For DC models only - Clockwise : Batteries discharging, Counterclockwise : Batteries charging.

### Last Gate Position/Condition

When the gate moves or stops, the display will show the status for up to one minute.

- Stop is displayed as **St**
- Full Close is displayed as **FC**
- Full Open is displayed as **FO**
- Entrapment is displayed as **En**

### Reverse Delay

If the gate travel direction is reversed from a user activation or reversing device, and a reverse delay is set, the display will count down the delay time in seconds before the operator restarts.

### Run Timer

While the gate is opening or closing, the number of seconds running time is displayed.

## Error Indications

During abnormal operation, the Controller's displays and beeper will indicate the error condition that has occurred.

### Entrapment

If an entrapment condition occurs detected by two repeated open or close obstruction triggers, the Controller will lock the operator out. To reset the Controller press the **STOP** button.



**WARNING**



**The Stop and/or Reset button must be located in the line-of-sight of the gate. Activation of the reset control shall not cause the operator to start.**

### COMM LINK Connection Failure

In dual gate installations, if there is a connection failure between the two operators, the **COMM LINK** indicator will blink once a second. During this condition the gate will not operate, except if triggered by the **FIRE DEPT** input, which functions normally.

## MGT Obstacle Transmitter Trouble

If any MGT transmitters are used with the operator, their supervision feature will alert the Controller if there is any trouble with the transmitter. MGT transmitters send hourly status reports and will send low battery reports when the transmitter has a low battery. The MGT transmitters also have a tamper detection switch that will trigger when their case is opened.

When the Controller detects a low transmitter battery, a tamper signal, or missing transmitter status reports, the gate will still operate normally, but the beeper will change as follows:

- The Pre-start Alarm will beep twice as fast.
- The Run Alarm will beep twice as fast and continue for five minutes after the gate stops.
- The sounder will "chirp" every five seconds when the gate is idle.

Correct the trouble (close case, replace battery, or replace transmitter) to clear the obstacle transmitter trouble indications.

### Maximum Run Time Exceeded

If the Maximum Run Time is exceeded, the Controller stops the operator the same as if a double obstacle has occurred in an entrapment condition. The condition is cleared by pressing the **STOP** button.

CONTROLLER ERROR CAUSES AND INDICATIONS		
ERROR CAUSE	ERROR INDICATION	HOW TO CLEAR
TWO SAFETY REVERSALS (ON SINGLE GATE OR ON EITHER DUAL GATE)	En 00, CONTINUOUS ALARM BEEPER, GATE DISABLED	PRESS STOP BUTTON
MAXIMUM RUN TIMER EXCEEDED ON OPENING	En 01, AND <b>MAX RUN</b> LED, CONTINUOUS ALARM BEEPER, GATE DISABLED	PRESS STOP BUTTON, CLEARS CONTINUOUS ALARM, THEN DOUBLE BEEP EVERY 5 SECONDS UNTIL NEXT OPERATION
MAXIMUM RUN TIMER EXCEEDED ON CLOSING	En 02, AND <b>MAX RUN</b> LED, CONTINUOUS ALARM BEEPER, GATE DISABLED	PRESS STOP BUTTON, CLEARS CONTINUOUS ALARM, THEN DOUBLE BEEP EVERY 5 SECONDS UNTIL NEXT OPERATION
COMM LINK FAILURE	En 03, AND <b>COMM LINK</b> LED, CONTINUOUS ALARM BEEPER FOR 1 MINUTE, GATE DISABLED (EXCEPT FOR FIRE DEPT INPUT)	PRESS STOP BUTTON, CLEARS CONTINUOUS ALARM
GATE FULL OPEN RESULTING FROM FIRE DEPT INPUT	En 04, GATE DISABLED	PRESS STOP BUTTON
FAIL SAFE OR FAIL SECURE BECAUSE OF BATTERY VOLTAGE DROP BELOW 21.6 VDC DUE TO AC POWER LOSS	En 05, GATE DISABLED	BATTERY VOLTAGE MUST RISE ABOVE 24 VDC
OTHER CONTROLLER IN ENTRAPMENT (DUAL GATE)	En 06, GATE DISABLED	CLEAR ENTRAPMENT ON OTHER CONTROLLER (PRESS STOP)
LOW AC VOLTAGE AT CONTROLLER	En 07, GATE DISABLED	RESTORE AC POWER TO NORMAL LEVEL
INPUT TRIGGERED DURING ENTRAPMENT LOCKOUT	En 08, GATE DISABLED	PRESS STOP BUTTON
COMPATIBILITY PROBLEM	En 09, GATE DISABLED	UPDATE FIRMWARE AND RESET BOTH PAIRED CONTROLLERS
EEPROM PROBLEM	En 10, GATE DISABLED	TRY RESET, CALL TECH. SUPPORT
DC MOTOR MISMATCH	En 11, GATE DISABLED	REPROGRAM MOTOR TYPE OR CHANGE DC MOTOR BOARD, NEXT GATE MOVEMENT WILL RETRY DC MOTOR CHECK
MOTOR FAILURE	En 12, GATE DISABLED	CALL TECH. SUPPORT
AC POWER LOSS IN OPEN OR CLOSE IMMEDIATE POWER FAIL MODE	En 13	REAPPLY AC POWER
MAXIMUM RUN TIMER EXCEEDED AFTER AC POWER LOSS	En 14	BATTERY VOLTAGE MUST RISE ABOVE 24 VOLTS
MGT SUPERVISORY CONDITION (TAMPER, LOW BATTERY, MISSING HOURLY STATUS)	FAST BEEPS DURING PRESTART, FAST BEEP RUN ALARM, CHIRP EVERY 5 SECONDS AT IDLE	CLEARS WHEN MGT CONDITION CLEARS

## Troubleshooting

### Contacting Technical Support

For technical questions regarding Linear gate operators, contact the Technical Services Department at:

1-800-421-1587 from 5:00 AM to 4:30 PM Pacific time

### Operator fails to start

- A. If the operator has been running a large number of cycles, the motor may have become too hot and tripped its thermal overload breaker. Allow the motor to cool down and the thermal overload breaker will reset automatically.
- B. Make sure you have power at the master distribution panel and that the power has not been turned off.

### Motor operates, but gate does not move

- A. In operators with torque limiters and friction pad clutches, check for signs of slipping. You can mark the sprocket and clutch with a yellow or white grease pen and watch for the lines to move apart if slipping is taking place. Adjust the torque limiter tighter if this is the problem.
- B. Check for broken chain or worn belts.
- C. Check all setscrews on pulleys and sprockets and tighten them if necessary, and check for keys which may have fallen loose from keyways.

### Motor sounds like it is working harder than normal

- A. Make sure the gate is moving freely and without binding throughout its entire travel.
- B. Check the drive chain for obstructions (if the operator has one).
- C. If the operator has an internal brake mechanism, make sure it is releasing.

### Limit switch getting out of time

- A. Check the setscrews in limit cams for tightness. Replace if necessary.

### Gate stopping part way open or closed (but no visible obstruction)

- A. The Controller may have received a false obstruction input triggered by current sensing set too low. Make sure the gate moves freely through its entire travel before adjusting the current sensing.
- B. The Maximum Run Timer may have counted down and expired. This can be caused by having the timer set too low, if a chain or belt is broken, or if a sprocket or pulley is slipping. When the timer expires, the gate stops.
- C. An obstruction signal from an accessory wired to the obstruction input may have triggered falsely. Check the control board for lit indicators for any of the following inputs: safety, shadow/reset, open obstruction, close obstruction, stop, etc. If any are lit when the operator should be running, remove all devices hooked to that function and hook them up one at a time and try to run the operator until the problem device is found. Refer to Page 8 for details on the control board indicators.

### Gate staying open with automatic system

- A. If there are vehicle detectors used with the operator, one of the loops or loop detectors may be sending a false signal or needs to be reset. Observe the indicators on the loop detector. Unplug the detector and try running the operator.
- B. An opening or reversing device may be stuck or malfunctioning. Try disconnecting these devices and hook them back up one at a time and try running the operator until the malfunctioning device is found.
- C. Make sure the close limit switch isn't activated. If it is, the operator will think the gate is already closed.

### How to Order Replacement Parts

Use the part numbers listed on the following pages.

Contact your local Linear dealer or distributor to order parts.

1. Supply the model number and serial number of your operator.
2. Specify the quantity of pieces needed and order by part number and name of part.
3. State whether to ship by freight, truck, parcel post, UPS or air express.
4. State whether transportation charges are to be prepaid or collect.
5. Specify name and address of person or company to whom parts are to be shipped.
6. Specify name and address of person or company to whom invoice is to be sent

# Model SG Exploded View

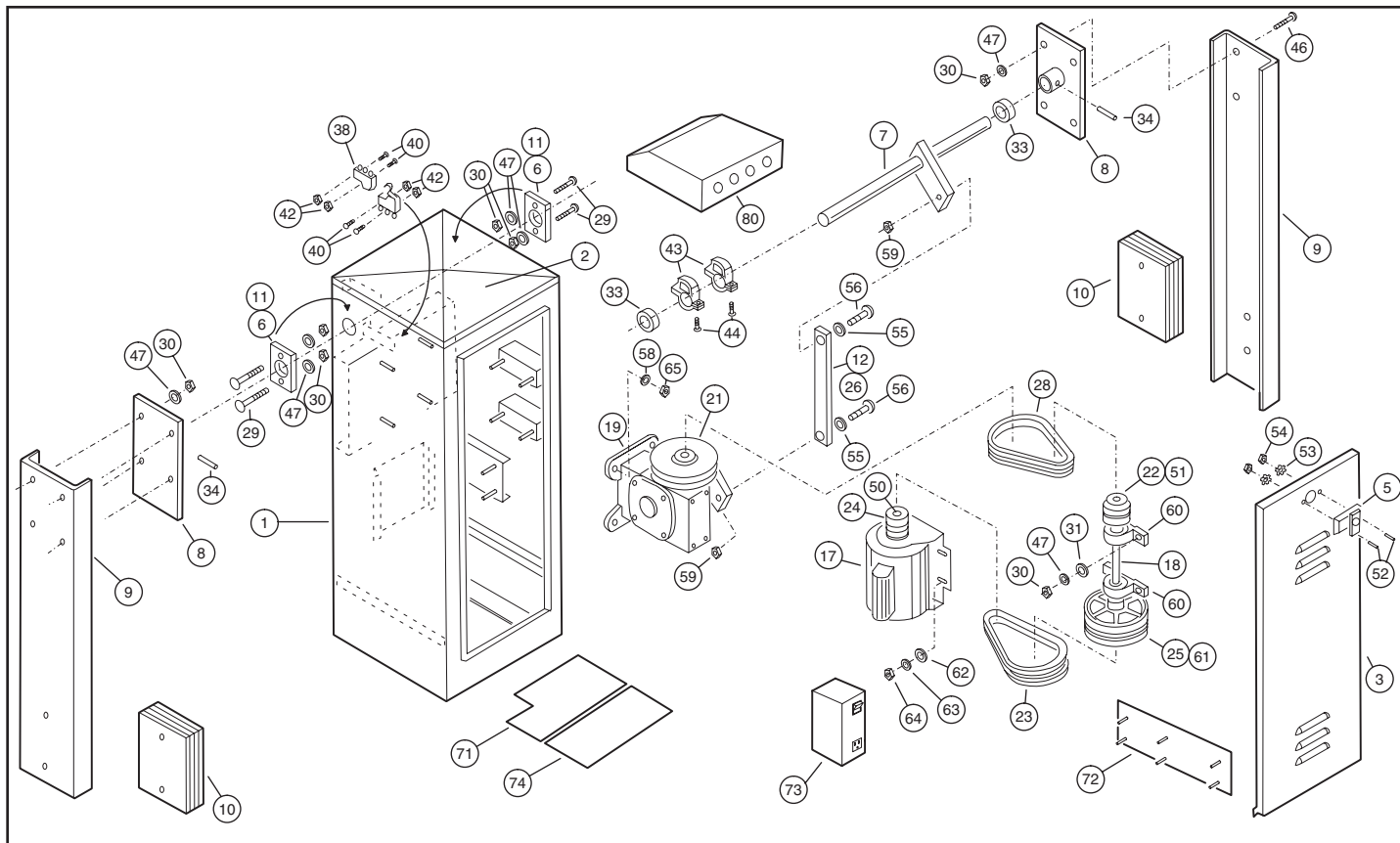

## MODEL SG MECHANICAL PARTS LIST

REF. #	PART #	DESCRIPTION
1	2110-780*	Enclosure only (without Door)
2	2100-2142*	Removable Enclosure Top
3	2110-318*	Louvered Door Assembly with Lock
	2100-2141	Latch for Enclosure Top
* Specify color and texture		
5	2220-008	Lock Assembly with Keys
6	2110-746	Bearing Block Assembly Kit
7	2110-034	Drive Shaft Assembly
8	2110-732	Gate Arm Flange
9	2100-1925-BT	Arm Attachment Channel
10	2100-1926-BT	Counterweight
11	2200-136	Flange Bearing only
12	2110-441	Connecting Link with Bearings
<b>MOTORS &amp; CAPACITORS</b>		
17	2500-2307	1/2 HP 115 VAC, 1 PH
	2500-2308	1/2 HP 208/230 VAC, 1 PH
	2500-2336	Capacitor for 2500-2307 Motor
	2500-2337	Capacitor for 2500-2308 Motor
18	2100-364	Intermediate Shaft
<b>GEAR REDUCER 75:1</b>		
19	2110-117	Gear Reducer and Crank Arm Assembly
21	2200-917	Reducer Pulley, 7" (2 required)
22	2200-918	Intermediate Pulley, 2" (2 required)
23	2200-936	V-Belt, (2 required) 25" Cogged
24	2200-235	Motor Pulley, 1-5/8"
25	2200-011	Intermediate Pulley, 6" (2 required)
28	2200-937	V-Belt, (2 required) 26" Cogged
29	2400-178	Carriage Bolt, 3/8"-16 x 1-1/2"
30	2400-015	Hex Nut, 3/8"-16
31	2400-017	Flat Washer, 3/8"
32	2400-182	Wing Nut, #10-32
33	2200-314	Set Collar, 1-1/4"
34	2400-474	Spring Pin, 3/8" x 2"
35	2400-043	Star Washer, #10
36	2400-032	Hex Nut, #10-32
37	2400-049	Screw, #8-32 x 3/8", Self-tap
38	2500-764	Limit Switch

REF. #	PART #	DESCRIPTION
40	2400-246	Screw, #6-32 x 2-1/4", Pan-head
42	2400-069	Keps Nut, #6-32
43	2300-028	Limit Cam
50	2400-238	Key, 3/16" x 3/16" x 1-1/4"
51	2400-254	Key 3/16" x 3/16" x 3", Intermediate Shaft
55	2400-188	Thrust Washer
56	2400-165	Shoulder Bolt, 1/2"-13 x 2"
60	2200-222	Bearing, Pillow Block
61	2400-133	Key 1/4" x 1/4" x 2-1/4", Intermediate Shaft
71	2100-1804	Rear Accessory Shelf
72	2100-1879	Power Box Mounting Plate
73	2510-422	115 VAC Power Box Assembly
	2510-430	230 VAC Power Box Assembly
74	2100-1820	Front Accessory Shelf
77	2520-523	Wiring Harness Assembly (not shown)
	2100-2143	Power Box Mounting Strap
80	2500-2393	APeX Module
	2100-2104	APeX Mounting Plate
	2300-1025	Plastic Cover Only
	2510-423	Knob Kit
	2400-343	1/4-20 Tinnerman Clip



# Model SG-D Exploded View

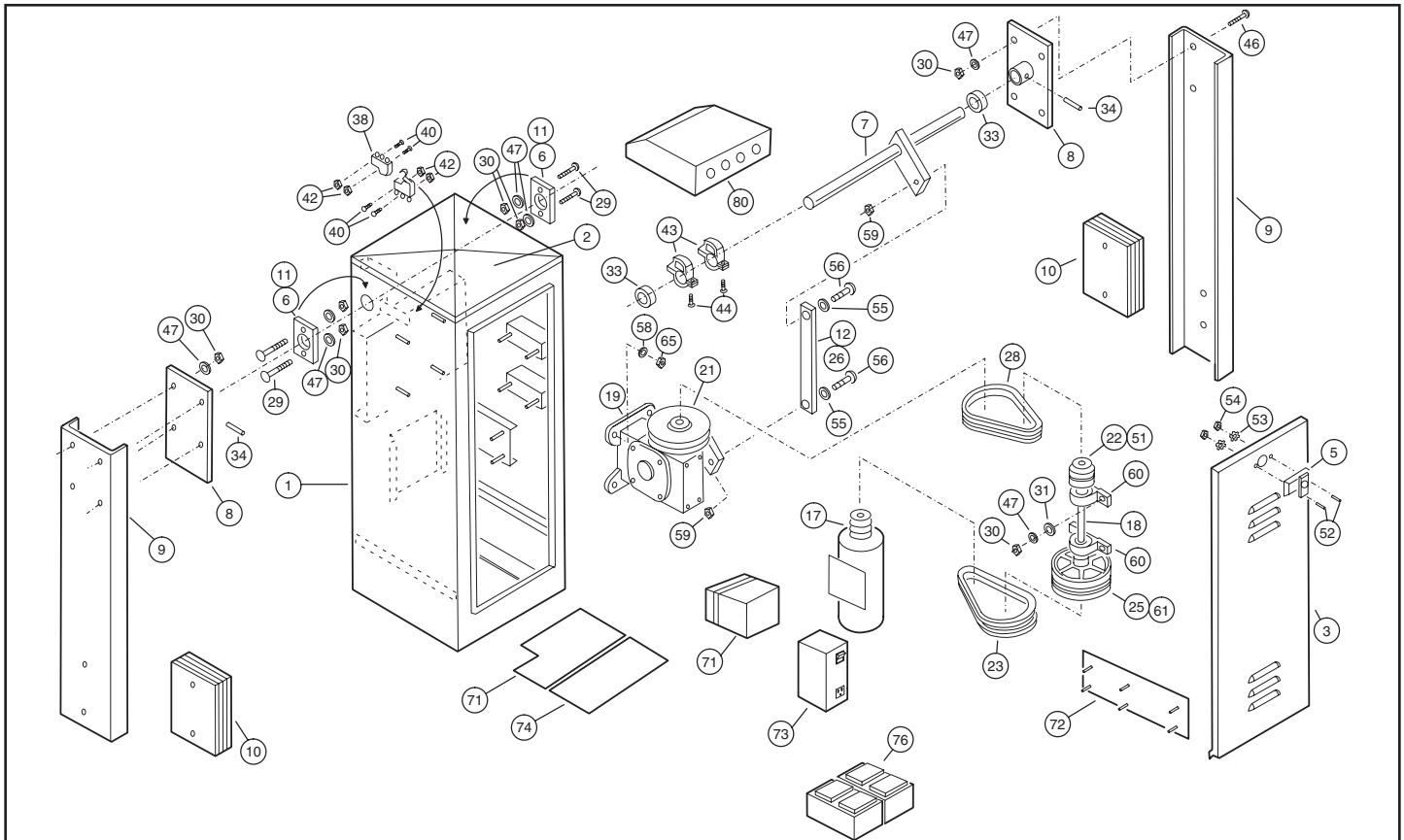

MODEL SG-D MECHANICAL PARTS LIST		
REF. #	PART #	DESCRIPTION
1	2110-780*	Enclosure only (without Door)
2	2100-2142*	Removable Enclosure Top
3	2110-318*	Louvered Door Assembly with Lock
	2100-2141	Latch for Enclosure Top
* Specify color and texture		
5	2220-008	Lock Assembly with Keys
6	2110-746	Bearing Block Assembly Kit
7	2110-034	Drive Shaft Assembly
8	2110-732	Gate Arm Flange
9	2100-1925-BT	Arm Attachment Channel
10	2100-1926-BT	Counterweight
11	2200-136	Flange Bearing only
12	2110-441	Connecting Link with Bearings
<b>MOTOR</b>		
17	2500-1902	Motor 24VDC
	2510-243	Brush Replacement Kit
	2110-834	Motor Mounting Bracket (not shown)
18	2100-364	Intermediate Shaft
<b>GEAR REDUCER 75:1</b>		
19	2110-117	Gear Reducer and Crank Arm Assembly
21	2200-917	Reducer Pulley, 7" (2 required)
22	2200-918	Intermediate Pulley, 2" (2 required)
23	2200-1003	V-Belt, (2 required) 23" Cogged
24	2200-235	Motor Pulley, 1-5/8"
25	2200-011	Intermediate Pulley, 6" (2 required)
28	2200-937	V-Belt, (2 required) 26" Cogged
29	2400-178	Carriage Bolt, 3/8"-16 x 1-1/2"
30	2400-015	Hex Nut, 3/8"-16
31	2400-017	Flat Washer, 3/8"
32	2400-182	Wing Nut, #10-32
33	2200-314	Set Collar, 1-1/4"
34	2400-474	Spring Pin, 3/8" x 2"
35	2400-043	Star Washer, #10
36	2400-032	Hex Nut, #10-32
37	2400-049	Screw, #8-32 x 3/8", Self-tap
38	2500-764	Limit Switch
40	2400-246	Screw, #6-32 x 2-1/4", Pan-head

REF. #	PART #	DESCRIPTION
42	2400-069	Keys Nut, #6-32
43	2300-028	Limit Cam
50	2400-238	Key, 3/16" x 3/16" x 1-1/4"
51	2400-254	Key 3/16" x 3/16" x 3", Intermediate Shaft
55	2400-188	Thrust Washer
56	2400-165	Shoulder Bolt, 1/2"-13 x 2"
60	2200-222	Bearing, Pillow Block
61	2400-133	Key 1/4" x 1/4" x 2-1/4", Intermediate Shaft
72	2100-1995	Power Disconnect Box and Transformer Mounting Bracket
73	2510-432	Power Box Assembly
	2500-2411	Power Switch
	2500-2413	Power Outlet
	2500-2473	Relay, 24 VDC
	2500-1768	Bridge Rectifier
	2500-1819	Fuse Holder
	2500-1748	Fuse, 10 Amp, Slow-Blow
74	2100-1804	Rear Accessory Shelf
75	2100-1820	Front Accessory Shelf
76	2510-182	Battery Assembly (Linear supplied - some distributors supply other batteries)
	2500-1118	Battery, 12V (2 required)
	2520-524	Wiring Harness Assembly (not shown)
77	2100-2143	Power Box Mounting Strap
80	2510-439	APeX Module and DC Motor Board Assembly
	2500-2393	APeX Module
	2500-2399	APeX DC Motor Module
	2100-2104	APeX Mounting Plate
	2300-1025	Plastic Cover Only
	2510-423	Knob Kit

## Model SG & SG-D Arm Parts List

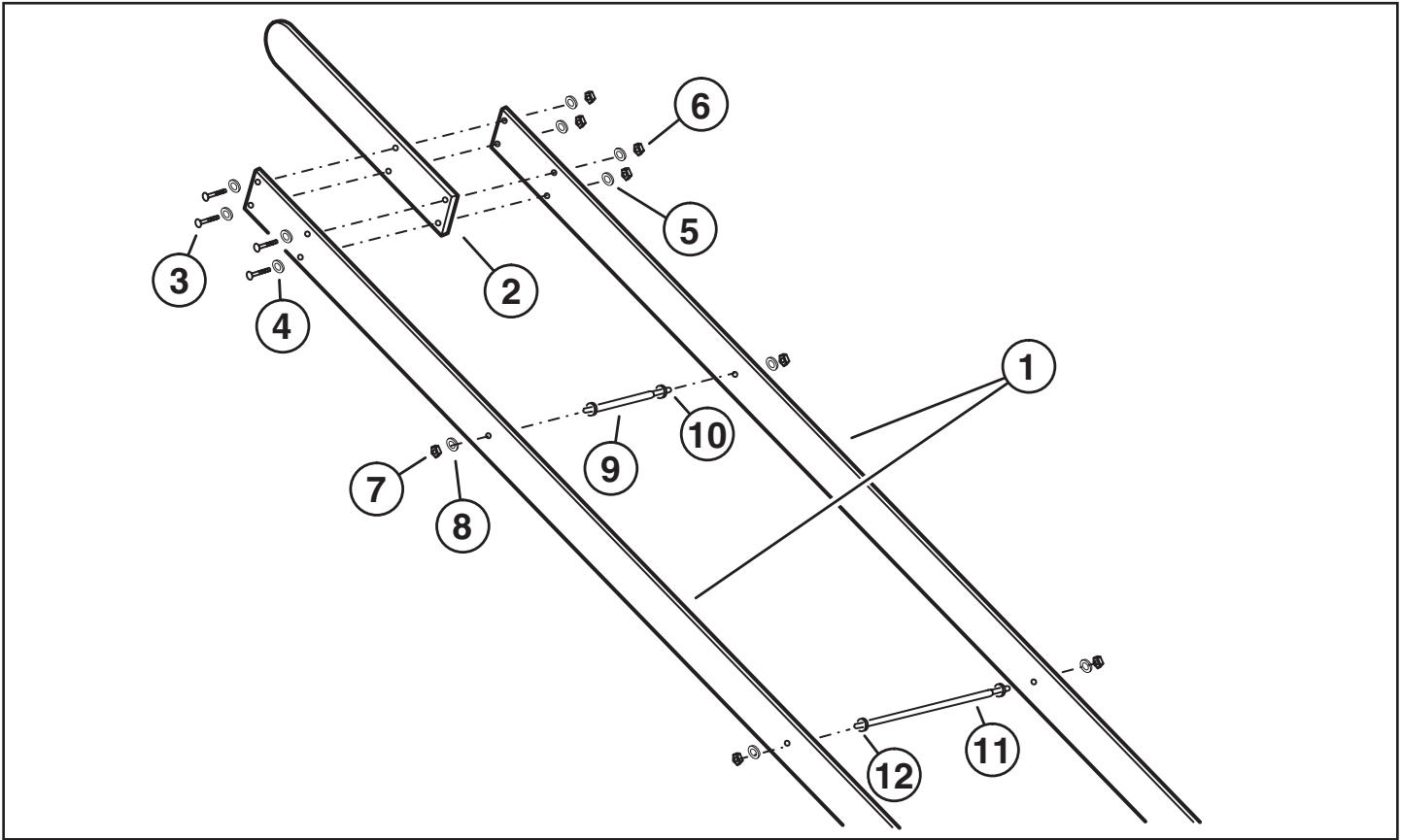

MODEL SG & SG-D ARM PARTS LIST		
REF. #	PART #	DESCRIPTION
	2700-082	Arm Assembly, complete with hardware
	2700-082-NOHDWE	Arm Assembly, less hardware
	2110-756	Hardware only
1	2100-495	Wood Arm, 1" x 6" x 16' (2 required)
2	2100-496	Wood Extension Arm, 1" x 6" x 10'
3	2400-108	Screw, 3/8" -16 x 3" hex head
4	2400-017	Flat Washer, 3/8"
5	2400-016	Lock Washer, 3/8"
6	2400-015	Hex Nut, 3/8" -16
7	2400-418	Nylon Lock Nut, 1/2" - 13
8	2400-376	Flat Washer, 1/2"
9	2100-1917	Mechanical Tube, 8" long
10	2100-1963	Threaded Rod, 1/2" - 13 x 12" long
11	2100-1916	Mechanical Tube, 18" long
12	2100-1962	Threaded Rod, 1/2" - 13 x 22" long
	2300-663	Yellow/Black 2" Caution Tape, per yard



## Model SG and SG-D Maintenance

### **⚠ WARNING ⚠**

**Always disconnect power from operator before servicing.  
Keep clear of gate during operation.**

### **Battery Maintenance**

The gel-cell batteries in this operator require no routine maintenance. For assured continued performance, they should be replaced every year. If power is to be removed for one week or more, disconnect the negative wire from the batteries as this will prevent deep discharging. Fully charge before use after storage or upon initial installation.

## **Preventative Maintenance**

### **General**

Linear gate operators are designed for many years of trouble-free operation and, under recommended operating conditions, will require only minimal maintenance. To ensure that a unit is ready for operation at all times, and to preclude serious damage or failure, inspect the unit systematically. Proper adjustments and lubrication should be made as recommended.

### **Lubrication**

- ✓ **Bearings** — For models which have pillow block style bearings with grease fittings, lubricate at least twice a year with a lithium complex based, petroleum oil NLGI 2 rated grease. Oilite and precision sealed bearings do not require additional lubrication.
- ✓ **Motor** — Motors have sealed ball bearings and do not require further lubrication. If bearing noise develops after several years of operation, bearings should be replaced by a motor repair company, or the motor should be replaced if necessary.
- ✓ **Barrier Gate Arm** — Check all bolts for proper tension and tighten if necessary. If the arm has been warped or damaged, replace as necessary.

### **6-Month Preventative Maintenance**

1. For operators which utilize torque limiting clutches, check for proper tightness. If there appears to be dust from wear on the pads, inspect the pads and replace if necessary. If the clutch cannot be adjusted tightly enough to move the gate without slipping, the pads must be replaced.
2. For operators with V-belts, inspect for wear and replace as necessary. Check for proper tension and adjust if required. Check all pulley setscrews for tightness and tighten if necessary.
3. For operators with internal chain drives, inspect chain and sprockets for wear and replace if necessary. Check for proper tension and alignment, and adjust if required. Check all hub sprocket setscrews and tighten if required.
4. Check limit switches and limit actuators (cams, limit nuts, etc.) for wear and replace as required. In rotary limit switch assemblies, wipe the limit shaft clean and apply a light coating of dry lubricant.
5. Inspect all nuts and bolts for proper tightness and tighten as necessary.
6. Check all reversing devices for proper function. Inspect all contact edges for wear and replace if required. Check photoeyes for proper alignment and function.
7. Check current sensing for proper adjustment when finished with inspection and maintenance.
8. Inspect the installation area. Are all the warning signs intact and visible? If they are missing or need replacing, contact Linear. Be sure there are no control stations mounted within reach of the gate. Review safety literature with the customer and advise them to remove any such stations found.

### **FCC Notice**

This device complies with FCC Rules Part 15 and Industry Canada Rules & Regulations. Operation is subject to the following two conditions: (1) This device may not cause harmful interference and (2) this device must accept any interference received, including interference that may cause undesired operation.

# Gate Operator Installation Checklist

---

INSTALLER    CUSTOMER

- |                          |                          |  |
|--------------------------|--------------------------|--|
| <input type="checkbox"/> | <input type="checkbox"/> | 1. The gate has been checked to make sure it is level and moves freely in both directions.   |
| <input type="checkbox"/> | <input type="checkbox"/> | 2. Potential pinch areas less than 6" have been guarded so as to be inaccessible <b>OR</b> have contact and/or non-contact obstruction sensing devices installed.  |
| <input type="checkbox"/> | <input type="checkbox"/> | 3. The installer has installed one or more contact or non-contact obstruction sensing devices, in compliance with UL325 requirements for this installation.  |
| <input type="checkbox"/> | <input type="checkbox"/> | 4. If pedestrian traffic is expected, a separate pedestrian gate has been installed, a minimum of seven feet from the gate. The customer has been informed that <u>all pedestrian traffic must use the pedestrian gate.</u>  |
| <input type="checkbox"/> | <input type="checkbox"/> | 5. Warning signs have been installed on each side of the gate in highly visible locations. The customer has been informed that these signs must remain at all times.   |
| <input type="checkbox"/> | <input type="checkbox"/> | 6. There are no controls installed on the gate operator, or within seven feet of the gate.   |
| <input type="checkbox"/> | <input type="checkbox"/> | 7. The installer has properly adjusted the obstruction sensing feature and has tested the gate to make sure that the gate stops and reverses a short distance with minimal resistance applied (40 lbs. on a swing gate at the end of the gate, 75 lbs. on a slide gate)                |
| <input type="checkbox"/> | <input type="checkbox"/> | 8. The installer has instructed the customer in the proper use of the gate operator and reviewed all of the operational functions, obstruction sensing devices, warning beeper and reset, etc.   |
| <input type="checkbox"/> | <input type="checkbox"/> | 9. The installer has instructed the customer in the proper use of the operator's manual disconnect feature. The manual disconnect must never be used while the gate is in motion. The power switch must be turned off before using the manual disconnect and disengaging the operator. |
| <input type="checkbox"/> | <input type="checkbox"/> | 10. The installer has reviewed all safety instructions with the customer, and has left the safety instructions and owner's information sheets for their reference.   |
| <input type="checkbox"/> | <input type="checkbox"/> | 11. The installer has answered any questions the customer has regarding the operation of the gate operator and gate operator safety precautions.   |
| <input type="checkbox"/> | <input type="checkbox"/> | 12. The installer has explained to the customer that a regular maintenance schedule for both the gate and the gate operator is recommended.  |

By signing this installation checklist, I/we hereby certify that each item listed and checked above has been covered by the installer and is clearly understood by the customer.

\_\_\_\_\_  
Customer's Signature

\_\_\_\_\_  
Date

\_\_\_\_\_  
Installer's Signature

\_\_\_\_\_  
Date